



Europäisches Patentamt
European Patent Office
Office européen des brevets



Publication number: **0 430 559 B1**

EUROPEAN PATENT SPECIFICATION

Date of publication of patent specification: 01.03.95 Int. Cl.⁶: **A24F 47/00**

Application number: **90312657.1**

Date of filing: **20.11.90**

Flavor-delivery article.

Priority: **01.12.89 US 444818**

Date of publication of application:
05.06.91 Bulletin 91/23

Publication of the grant of the patent:
01.03.95 Bulletin 95/09

Designated Contracting States:
AT BE CH DE DK ES FR GB GR IT LI NL SE

References cited:
EP-A- 0 358 002
US-A- 3 200 819

Proprietor: **Phillip Morris Products Inc.**
3601 Commerce Road
Richmond
Virginia 23234 (US)

Inventor: **Counts, Mary E.**
4506 Cutchaw Avenue
Richmond,
Virginia 23230 (US)
Inventor: **Hajaligol, Mohammad R.**
4509 Adelaide Avenue
Richmond,
Virginia 23234 (US)
Inventor: **Morgan, Constance H.**

3508 Quail Hill Court
Midlothian,
Virginia 23112 (US)
Inventor: **Smith, Ulysses**
P.O. Box 1834
Midlothian,
Virginia 23113 (US)
Inventor: **Sprinkel, Francis M.**
Route 4, Box 347
Glen Allen,
Virginia 23060 (US)
Inventor: **Utsch, Francis V.**
13000 Robious Road
Midlothian,
Virginia 23114 (US)
Inventor: **Losee Jr., D. Bruce**
3912 Park Avenue
Richmond Virginia 23221 (US)
Inventor: **Raymond, Wynn R.**
6401 Wilton Road
Chesterfield, Virginia 23832 (US)

Representative: **Lloyd, Patrick Alexander Des-**
mond et al
Reddie & Grose
16 Theobalds Road
London WC1X 8PL (GB)

EP 0 430 559 B1

Note: Within nine months from the publication of the mention of the grant of the European patent, any person may give notice to the European Patent Office of opposition to the European patent granted. Notice of opposition shall be filed in a written reasoned statement. It shall not be deemed to have been filed until the opposition fee has been paid (Art. 99(1) European patent convention).

Description

This invention relates to electrically-heated flavor-delivery articles, and to methods and apparatus for electrically heating a flavor source in order to derive flavor therefrom. These articles are referred to as smoking articles although that term does not necessarily mean that the flavor source is heated to combustion.

Smoking articles utilizing electrical power for heating and thereby releasing flavor from tobacco and other compounds may have certain advantages over conventional smoking articles. For example, electrically-heated smoking articles produce the taste and sensation of smoking without burning of tobacco. Also, electrically-heated articles do not produce a visible aerosol between puffs. However, there have been various technical problems with electrically-heated articles.

It is desirable to maintain the smoking article at a substantially consistent temperature during operation to produce a relatively consistent release of flavor from puff to puff. The smoking article must reach operating temperature quickly, it must not overheat, and it must remain at the operational temperature long enough to generate/release designed flavors, vapors, and aerosols (hereinafter "flavor components"). The article should also be efficient in terms of its power consumption.

US-A-3200819 discloses a device in which flavor components are released from a flavor cartridge as air inhaled by the user is drawn over the cartridge. A battery powered heating bulb heats the air and flavor component mixture as it passes over the bulb before delivery to the user.

EP-A-358002 published after the priority date of this application and relevant as prior art only under Article 54(3) EPC discloses a system in which an electrically heated wire is impregnated with flavor components which are released on heating. On consumption of the flavor components the heating element is discarded and a fresh heating element employed.

In view of the foregoing, it is an aim of the invention to provide an improved electrically-heated device for generating flavor components.

The invention provides a smoking article comprising a flavor-generating medium, an electrical heating element, and electrical energy delivery means, the flavor-generating medium being detachable from the electrical heating element, characterised in that the electrical heating element is in thermal contact with the flavor-generating medium, in that the electrical energy delivery means delivers electrical energy to the heating element to cause the heating element to heat the flavor-generating medium to release flavor components therefrom, and by regulating means for regulating

the amount of electrical energy delivery by the energy delivery means.

The invention also provides a smoking article comprising a flavor-generating medium, an electrical heating element, and electrical energy delivery means for delivering electrical energy to the heating element, characterised in that the electrical heating element is in thermal contact with the flavor-generating medium, in that delivery of electrical energy to the heating element causes the heating element to heat the flavor-generating medium to release flavor components therefrom, and by regulating means for regulating the amount of electrical energy delivered by the electrical energy delivering means including means for applying a predetermined temperature controlling cycle to the flavor-generating medium.

The invention further provides apparatus for delivering flavor from a flavor-generating medium, comprising a combination of a non-combustible smoking article and a heating apparatus, the smoking article comprising a hollow tube, and a flavor-generating medium characterised in that the flavor-generating medium generates flavor components when heated to a predetermined temperature, and by thermally conductive capturing means connected to the hollow tube for capturing the flavor-generating medium while allowing air to pass through to capturing means, and in that the heating apparatus comprises a housing having a recess for receiving the capturing means, a heating element for heating the flavor-generating medium and arranged in thermal contact therewith when the capturing means is arranged in the recess and means for selectively applying power to the heating element and therethrough to the flavor-generating medium thereby to release the flavor components.

The invention furthermore provides methods of deriving flavor from such smoking articles or apparatus. Preferred features of the invention are set out in the dependent claims.

An article embodying the invention has the advantage that it provides an electrically-heated article which may reduce or eliminate certain by-products of burning. It has the further advantage that flavor components may be released consistently from puff to puff. A further advantage of an article embodying the invention is that flavor component delivery can be controlled with a minimal amount of input energy.

One embodiment of the invention has the advantage of a passive system for controlling predictably the temperature of the heating element.

An article made according to a preferred embodiment of the invention releases a controlled amount of flavor components. A heating element raises the temperature of a flavor-generating medium to a predetermined temperature, which is

below the temperature at which burning begins. For example, a non-burning article is formed by surrounding a positive temperature coefficient thermistor with the flavor-generating medium to be heated, capturing the material and heating element in a tube (which typically may be foil-lined), attaching a filter, and providing an outer wrapper for the article. The flavor-generating medium is heated by applying electrical energy to the thermistor. The thermistor draws electrical current, which raises the temperature of the thermistor to some predetermined "transition" temperature. The transition temperature is a known value, determined by the composition of the thermistor, at which the device's temperature stabilizes.

In another embodiment, a control system applies a predetermined, timed voltage cycle to the heating element, or temperature cycle to the flavor-generating medium, pulsing the temperature of the medium to the preferred temperature to produce flavor components. This multi-stage operation reduces power consumption, because the flavor generator is at elevated temperatures for only short periods of time.

In addition to providing flavor components for enjoyment, articles made in accordance with this invention provide a means for regulating the delivery of the flavor components produced by the article. The amount of flavor released from the flavor-generating medium varies according to the temperature to which the flavor-generating medium is heated. By selecting heating elements, power supplies, and control systems with the proper operating characteristics, articles of different deliveries can be produced.

Embodiments of the invention will now be described, by way of example and with reference to the drawings, in which:

FIG. 1 is a partially fragmentary perspective view of an illustrative embodiment of a non-burning article made in accordance with the principles of this invention;

FIG. 2 is an alternative embodiment of the non-burning article of FIG. 1;

FIG. 3 is a longitudinal sectional view of another illustrative embodiment of a non-burning article constructed in accordance with this invention;

FIG. 4 is a graph of the temperature characteristic of a typical thermistor used as a heat source for the non-burning article of this invention;

FIG. 5 is a graph illustrating the power consumed by a thermistor to achieve and maintain the temperatures depicted in FIG. 4;

FIG. 6 is a longitudinal sectional view of another illustrative embodiment of a non-burning article constructed in accordance with this invention;

FIG. 7 is a partially fragmentary longitudinal sectional view of an illustrative embodiment of a

non-burning article constructed in accordance with this invention having an active control circuit;

FIG. 8 is an illustrative embodiment of the active control circuit of the article of FIG. 7;

FIG. 8a is a schematic diagram of an alternative active control circuit;

FIG. 9 is a longitudinal sectional view of an illustrative embodiment of a non-burning smoking article which uses a capacitor and battery as a power supply;

FIG. 10 is a schematic diagram of the electrical connections for the article of FIG. 9;

FIG. 11 is a partly schematic diagram of a device constructed in accordance with this invention for supplying electrical energy to the articles of this invention;

FIG. 12 is an alternative embodiment of the device of FIG. 11;

FIGS. 13 and 14 are perspective views of appliance-type devices for supplying electrical energy to the articles of this invention;

FIG. 15 is a longitudinal sectional view of an alternative embodiment of a non-burning article of this invention;

FIG. 16 is a partly schematic diagram of apparatus for heating the article of FIG. 15; and

FIG. 17 is an alternative embodiment of the apparatus of FIG. 16.

Referring now to the drawings, FIG. 1 shows an article, designated generally by reference numeral 10, which typically includes flavor-generating medium 12, a heating element 14, and a power source 16, which are surrounded by an outer tube or overwrapper 18. Flavor-generating medium 12 typically may be formed in a packed bed or as an extruded rod disposed around heating element 14, and is then typically encased in an inner, thermally-insulating tube 20. Flavor-generating medium 12 is captured within tube 20 by perforated front and rear clips 22 and 24, respectively. Electrical energy from power source 16 is applied to the terminals of heating element 14, which heats the flavor-generating medium to produce an flavor component. Air holes 26 are provided in outer wrapper 18 to permit outside air to be drawn through flavor-generating medium 12. The outside air mixes with the flavor components, and the mixture is drawn through front clip 22 and filter 28 when the consumer draws on the article. Article 10 is separable along line A-A to permit the consumer to replace expended flavor-generating medium and filter materials, and to access power source 16.

FIG. 2 shows an alternative embodiment of article 10 in which energy is supplied to heating element 14 from an external source rather than from internal power source 16. Energy is transmitted to the contacts of heating element 14 via con-

necter pins 30. A heater base 32, which partially extends within tube 20, supports and properly positions connector pins 30. Energy may be supplied to connector pins 30 through wires extending to an external power source, permitting article 10 to be operated while the power is connected. Alternatively, the article may be plugged directly into the external power source while heating and then removed from the power source for use. One skilled in the art could modify the embodiments of the articles described herein to utilize either internal or external power sources.

Flavor-generating medium 12 typically is placed around heating element 14. Alternatively, the heating element may surround the flavor-generating medium. Flavor components are released from medium 12 when the temperature of medium 12 has been raised to between about 100°C and 500°C. The preferred temperature range for generating flavor components is between 120°C and 400°C, and the most preferred range is between 200°C and 350°C. The amount of flavor components produced by the article, and consequently, the amount of flavor released, depends upon the temperature, quantity, and concentration of flavor-generating medium 12. Flavor-generating medium 12 may be similar to the flavor pellets shown in commonly assigned United States patent application Serial No. 07/222,831, filed July 22, 1988, hereby incorporated by reference in its entirety. Flavor-generating medium 12 may include tobacco or tobacco-derived materials. Alternatively, medium 12 may be peppermint, fruit flavors, or other similar flavors.

Heating element 14 may be formed using a variety of materials. In a preferred embodiment, heating element 14 is a resistive wire coil (such as tungsten, tantalum, or nichrome) disposed within an insulating tube which typically may be paper, foil, carbon, plastic, or glass. Alternatively, the heater may be formed with graphite or ceramics, and can be formed with a protective sheath of these materials.

The heating element is designed to heat flavor-generating medium 12 directly or to heat outside air before it is drawn through medium 12. Referring now to FIG. 3, article 34 includes a first heating element 14 in contact with flavor-generating medium 12, and a second heating element 14' for preheating air drawn into tube 20 before it enters bed 12. When a puff is drawn on filter 28, outside air is drawn through air holes 26 formed in outer wrapper 18. The air is drawn through a passageway 36 which is formed between outer wrapper 18 and thermally-insulating tube 20 by spacer rings 38 and 40. The air exits passageway 36 and enters tube 20 via air holes 42, and is drawn past heater 14' and through the heated flavor-generating me-

dium. The mixture of heated air and flavor components is drawn through filter 28 for the consumer's use.

A controlled flavor-generating medium temperature (or a consistent heating temperature in a pulse-heated system) is required to ensure a substantially consistent release/generation of flavor components. Flavor-generating medium 12 typically is maintained at a controlled temperature by means of a control system. Control systems suitable for use with this invention may be either "passive" systems or "active" systems. A passive control system is one that uses heating element 14 or power source 16 themselves to regulate the temperature of flavor-generating medium 12 or the amount of power applied to the heating element. An active control system uses an additional components such as an electronic control circuit, or requires participation from the consumer, to consistently heat the flavor-generating medium.

In a preferred embodiment of the invention, the article utilizes a passive, coupled system to control the heating process and to control the amount of flavor component generated. The characteristics of the components in the coupled system are selected to maintain flavor-generating medium 12 at a controlled temperature throughout operation. The critical components of the coupled system include flavor-generating medium 12, heating element 14, and power source 16. This type of coupled control system is most effective in articles which have a self-contained power source.

The coupled system works as follows. Power source 16 discharges electrical energy to heating element 14. Heating element 14 converts the discharged electrical energy into heat. The thermal masses and material properties of heating element 14 and flavor-generating medium 12 rapidly absorb the heat and prevent smoking article 10 from overheating. More energy is released at the beginning of operation, when power source 16 is fully charged. After a short period of operation, power output from power source 16 is reduced, because the power source has discharged most of its potential energy and because the internal resistance of power source 16 rises (due to its self-heating properties). The discharge characteristics of power source 16 change due to the discharge of energy to the heating element, and due to losses internal to the power source. Because flavor-generating medium 12 and heating element 14 retain heat generated during the initial high-energy discharge of power source 16, the temperature of flavor-generating medium 12 remains substantially constant, even as the electrical energy output of power source 16 is reduced. When the electrical energy of power source 16 is depleted, flavor-generating medium 12 may be removed and replaced with

fresh material, and power source 16 may be re-charged, prior to reuse.

A change in any one component of the coupled system affects the performance of the other components. Flavor-generating medium 12, heating element 14, and power source 16 must be empirically tailored to select the desired operating temperature of article 10. For example, a heating element having a lower resistance and lower mass would allow more current to flow, and would allow flavor-generating medium 12 to heat more quickly. Also, the thermal characteristics of flavor-generating medium 12 vary with the size and quantity of the pellets forming the flavor-generating medium. Increased surface area, resulting from smaller pellet size, permits flavor-generating medium 12 to absorb thermal energy at a quicker rate by providing more contact with the heating element and adjacent particles.

The amount of total particulate matter (TPM) released from a given flavor-generating medium is proportional to the time temperature history of the medium. For example, heating a 100 milligram sample of the material at 120°C typically can release two milligrams of TPM in a given time period. The same sample, heated to 280°C for the same amount of time, releases 22 milligrams of TPM. Thus, the delivery of the article may be regulated by selecting components of the coupled system to achieve a predetermined temperature.

In an equally preferred embodiment, heating element 14 is a positive temperature coefficient thermistor. A thermistor is a temperature-sensitive resistor which provides passive temperature control. When the thermistor reaches a predetermined temperature (i.e., the so-called "transition temperature" of the thermistor), its electrical resistance greatly increases, reducing current flow through the thermistor and therefore the heating. If the temperature of the thermistor decreases, the electrical resistance also decreases, causing additional current to flow and heating to increase. The thermistor maintains a constant bed temperature by continually adjusting the current flow in response to thermistor temperature (and flavor-generating medium temperature). Positive temperature coefficient thermistors suitable for use in the present invention are commercially available, for example, from Murata Erie North America, 220 Lake Park Drive, Smyrna, Georgia 30080 (thermistor part No. PTH420AG100N032).

FIG. 4 is a graph of the temperature characteristic of a typical positive temperature coefficient thermistor. By selecting the appropriate thermistor, the transition or stabilization temperature may be selected to achieve a desired flavor strength for the article. FIG. 4 illustrates the rapid heating abilities of the thermistor. Because of its

chemical composition, the positive temperature coefficient thermistor functions as a self-regulated heating device.

There are several advantages to heating the article with thermistors rather than conventional resistance heaters. Articles having thermistors do not require thermostats or control circuits to prevent overheating, provide a controlled surface temperature independent of ambient conditions, and provide a stable temperature almost independent of the supply voltage. These features make the device an excellent choice for heating flavor-generating media in articles because it provides a consumer with a relatively consistent delivery of flavor from puff to puff.

FIG. 5 is a graph of the power consumed by the thermistor to produce the temperatures shown in FIG. 4.

Articles embodying the present invention may utilize active control systems to regulate operation. One preferred system is a double heater/pulse design, shown in FIG. 6. A first heating element 14 maintains the temperature of flavor-generating medium 12 at a substantially constant temperature, below the temperature to which flavor-generating medium 12 must be heated to generate the desired aerosol. A second heating element 14' is pulsed with electrical energy to raise the temperature of the medium above the vaporization temperature to produce the desired flavor components.

Flavor-generating medium 12 is captured within tube 20, which may be a metal or other thermally conductive container. Heating element 14 surrounds and can be in thermal contact with tube 20 to heat the contents of the tube. Heating element 14 preferably heats the air drawn through passageway 36 before the air is drawn into tube 20. Heating element 14', which typically may be disposed within flavor-generating medium 12, is pulsed for a predetermined period with electrical energy from power source 16 to generate/release flavor components for each puff.

The double heater/pulse design of FIG. 6 provides two distinct advantages. First, less energy is required from power source 16 to provide the same flavor-generating capability as a constant-temperature system. The flavor-generating medium is maintained at a lower temperature for most of the operating period. A high temperature is not maintained; flavor-generating medium 12 is pulsed to the higher temperature for short periods, which consumes less energy. Second, the flavor components are generated in the short time period immediately prior to, and/or during, puffing. Nominal amounts of flavor components accumulate between puffs. This results in an improved flavor component delivery.

A more preferred embodiment of article 10 includes only a single heating element which contacts flavor-generating medium 12. The heating element provides both the constant, low-level heating between puffs, and the high temperature pulse for each puff.

A second type of active control system, shown in the smoking article 44 of FIG. 7, is an electronic control circuit 46 which regulates power delivered to a single heating element 14. Circuit 46 provides a predictable method for applying voltage and current to heating element 14, and thus for controlling the temperature of flavor-generating medium 12. Control circuit 46 has two operating modes for efficient power use: a "low power" mode for maintaining flavor-generating medium 12 at a predetermined low-level temperature (below the vaporization temperature) between puffs, and a "high power" mode for rapidly raising heating element 14 to its preferred, higher operating temperature. Circuit 46 typically provides a fixed lock-out time between high power operations to prevent inadvertent overheating of flavor-generating medium 12 by frequent high power operation.

Circuit 46 is connected to power source 16 by a double-pole, double-throw switch 48, which is shown in the "off" position in the drawing. When switch 48 is placed in the "on" position, the positive terminal of power source 16 is connected to the input terminals (pin 1) of voltage regulators 56 and 58. Regulators 56 and 58 are standard, commercially available integrated circuits (such as Models 7508 and LM317T, available from Radio Shack, Division of Tandy Corporation, Fort Worth, Texas). The negative terminal of power source 16 forms a ground reference for the circuit.

To operate smoking article 44, the consumer sets power switch 48 to the "on" position. Article 44 operates initially in the high power mode. Flavor-generating medium 12 is quickly heated to its preferred, higher temperature, enabling the consumer to puff article 44. When the time interval for the high power mode elapses, control circuit 46 enters the low power mode to maintain flavor-generating medium 12 at a reduced temperature. The consumer is prevented from initiating the high power mode for a predetermined lock-out period, to prevent overheating the smoking article. When the lock-out period has elapsed, the consumer may re-enter the high power mode by actuating a switch 50. The cycle is repeated each time switch 50 is actuated. When the consumer has finished, the expended flavor-generating medium may be replaced in preparation for the next use of the device.

Circuit 46 includes two timing circuits 60 and 62, which are based on standard (low power) integrated circuit (IC) timers 64 and 66 (such as

Model TLC555, also commercially available from Radio Shack). Timing circuits 60 and 62 control the low power and high power modes of operation, respectively. Voltage regulator 56, with pin 3 connected to ground, regulates the voltage to the resistor-capacitor (RC) network that determines the duration of the high power lock-out period.

Resistor 68 connects the output and voltage adjust pins (pins 2 and 3, respectively) of voltage regulator 58, causing regulator 58 to function as a current limiter when circuit 46 operates in the low power mode. The output of regulator 58 is bypassed during the high power mode.

The regulated output voltage (pin 2) of voltage regulator 56 is connected to the positive power terminal (pin 8) of timer 64 and to an RC network. The negative power terminal (pin 1) of timer 64 is grounded. The RC network includes a variable resistor 70, a fixed resistor 72, and a capacitor 74. The output of timer 64 (pin 3) is controlled by the RC network and is triggered by a negative pulse on pin 2, which in turn, is caused by grounding pin 2 through switch 50. The charging time is determined by the values of resistors 70 and 72, and capacitor 74, which are selected to obtain a charging time which typically may be in the range of about five to about thirty seconds, and preferably between ten and twenty seconds, and most preferably fifteen seconds.

Switch 50 is connected to the RC network between resistor 72 and capacitor 74 on one side, and is grounded on the other. Switch 50 discharges capacitor 74 when actuated, resetting the charging time of circuit 60 to zero, and generating an output at pin 3 of timer 64. When the voltage on capacitor 74 exceeds two-thirds of the supply voltage, the high power lock-out period elapses, and the consumer may again cause the circuit to enter the high power mode (to generate flavor components).

Pin 2 (regulated output voltage) of regulator 56 connects to timing circuit 62 through the normally-open contacts of relay 76. When the output from pin 3 of timer 64 is high, the coil of relay 76 is energized, and the relay contact is closed. Power is then supplied to timing circuit 62. Timing circuit 62 includes timer 66 and a second RC network which includes variable resistor 78, fixed resistor 80, and capacitor 82. The charging time of the second RC network is determined by the values of resistors 78 and 80, and capacitor 82, which are selected to obtain a charging time which typically may be in the range of about 0.2 to about 4.0 seconds, preferably between 0.5 and 2.0 seconds, and most preferably between 1.2 and 1.6 seconds. This charging time controls the duration of the high power mode. The output of timer 66 (pin 3) is controlled by the second RC network, and becomes high when the voltage at pin 2 of timer 66

drops below one-third of the supply voltage. Pin 7 of timer 64 provides a discharge path for capacitor 82, to trigger the output at pin 3 of timer 66 and to reset timing circuit 62.

Variable resistors 70 and 78 permit adjustment of the charging time for timing circuits 60 and 62, respectively. In an alternative embodiment, resistors 70 and 72 and resistors 78 and 80 are replaced with a respective one of a single, fixed resistor. If the desired charging times are known and fixed, it is advantageous to use a single, fixed resistor for each pair, to reduce the size and complexity of circuit 46.

The output of timer 66 (pin 3) is connected to the coil of relay 86, and therefore controls the voltage across the coil of relay 88. Relay 88 controls whether heating element 14 is heating in the low power or high power mode, by controlling the voltage across output terminals 90. Relay 88 switches either the regulated current output of voltage regulator 58 (low power mode) or the positive voltage of power source 16 (high power mode) to output terminal 90. The contact of relay 88 is normally switched to terminal a, which is connected to the regulated current output (pin 2) of regulator 58. Terminal b of relay 88 is connected to the positive terminal of power source 16, through power switch 48. When relay 86 is energized, current flows from power source 16 and through relay 86, energizing the coil of relay 88. The contact of relay 88 then switches to terminal b. LED 54 connects the common contact of relay 88 with series resistor 92 (the resistor's second terminal is grounded). Resistor 92 is selected such that LED 54 is illuminated only during the high power mode.

Changing any component of control circuit 46 will affect the performance of the entire circuit, and thus affect the operation of article 44. In particular, changing the values of the resistors and capacitors which form the first and second RC networks of timing circuits 60 and 62 will alter the charging times of these circuits, and thus alter the duration of high power operation and the duration of the high power lock-out period. The optimal duration of each time interval is determined primarily by the characteristics of flavor-generating medium 12 and heating element 14. For example, a heating element having a lower electrical resistance would allow more current to flow, and would allow the flavor-generating medium to heat more quickly. This, in turn, might allow for a shorter high power operation.

A third type of active control system uses a temperature-sensing feedback loop to control the heating cycles applied to flavor-generating medium 12. For example, temperature-sensing devices such as thermocouples, thermistors, and RTDs may be used to sense temperature and regulate

the power flowing to the heating element to maintain a predetermined temperature. An illustrative embodiment of this control system is shown in FIG. 8a.

Referring now to FIG. 8a, heating element 14 is connected directly to a voltage supply, and is grounded through a normally-closed contact of a single pole, double throw relay contact 81. The relay is actuated under the control of a switched output set point controller 83 (Model AD595, manufactured by Analog Devices, Norwood, Massachusetts) via pin 9. The controller 83 is connected to the voltage supply via pin 11, and is grounded via pins 1, 4, 7, and 13. A "K" type thermocouple 85 has an iron and a constantan pin, which are connected to pins 1 and 14 of controller 83, respectively. Controller 83 is connected (via pin 8) to an output voltage of about 2.5 volt from pin 2 of a voltage regulator 87 (Model AD580, manufactured by Analog Devices, Norwood, Massachusetts). Voltage regulator 87 is connected to a voltage supply via pin 1, and is grounded via pin 3.

When power is initially switched on, current flows through the heater until the predetermined temperature, set by the voltage reference (at pin 8), is reached. If the voltage reference is 2.5 volts, the set point temperature is 250 °C (the temperature set point corresponds to approximately 100 °C per volt). Once the set point temperature is reached, the output of controller 83 is equal to the supply voltage, and the relay is energized. At this point, the normally-closed relay contact opens, causing the current flow through the heater to cease. The temperature will then drop below the set point temperature, causing the relay to deenergize, closing the normally-closed contact. This feedback cycle continues, maintaining the heater temperature at about the set point temperature.

The set point temperature of the circuit of FIG. 8a can be varied by changing the set point voltage at pin 8 of controller 83. The components of this circuit could be changed to accomplish the same goal. For example, either a solid state relay or transistors could be used in place of relay 81. Also, a custom integrated circuit could be made which incorporates all of the functions in the discrete circuit. This type of circuit could be modified to use an RTD, or other temperature sensors and transducers, in place of thermocouple 85.

Power can be supplied to the articles of this invention in a variety of ways. Broadly classified, power source 16 may be an internal or an external source. Internal power sources are disposed within the article (see FIG. 1), creating a self-contained system. External sources are disposed exterior to the article, and typically are connected to the article (FIG. 2) via connecting pins 30.

Internal power sources 16 typically are rechargeable nickel cadmium (NiCd) batteries, because NiCd batteries discharge power relatively consistently throughout the discharge cycle. However, power source 16 may be any rechargeable or disposable battery, such as a rechargeable lithium manganese dioxide battery or a disposable alkaline battery. Power source 16 typically has sufficient capacity to supply 20-500 milliamp-hours, and to produce a voltage of 2.4 volts. In a preferred embodiment, power source 16 is two, 1.2 volt, 80 milliampere batteries, connected in series. Batteries of this capacity are capable of powering a single, "10-puff" article. These batteries will provide sufficient energy for approximately five minutes of operation.

In an alternative embodiment of the smoking article, designated generally by reference numeral 95 and shown in FIG. 9, power source 16 includes a capacitor 94 and a battery 96 for charging the capacitor. Battery 96 may be discharged slowly, in the period between puffs, to charge capacitor 94. Unlike a capacitor, a battery is not well suited to quickly discharge stored energy. Battery 96 may power a significantly greater number of puffs when it is slowly discharged rather than quickly discharged. The battery/capacitor combination enables the use of batteries smaller in size and capacity, and permits the consumer to charge the battery less frequently than would be possible without the capacitor.

In another alternative embodiment, energy is coupled to the article by magnetic or electromagnetic induction, and rectified and conditioned prior to charging the capacitor. The external power source typically may be a specially designed ash-tray containing a suitable generator and inductor for coupling the magnetic or electromagnetic energy to the article.

Capacitor 94 delivers a predetermined amount of energy to heating element 14 to provide a controlled delivery for a single puff. Capacitor 94 is recharged between each puff to minimize the charge storage capacity required. Capacitor 94 discharges the maximum energy early in the discharge cycle, quickly raising the temperature of flavor-generating medium 12 to the pulse temperature. As capacitor 94 discharges, the operating voltage of the capacitor reduces, causing a correspondingly reduced energy release. The reduced energy release maintains the heating element temperature and flavor component generation. Capacitor 94 must have sufficient capacitance to store enough energy to power the heating pulse for a single puff. The capacitance and the resistance of heating element 14 must be selected to establish a desired capacitor discharge time constant. Capacitors suitable for use in accordance with the present

invention may be selected according to the following equation:

$$C = 2E / V^2,$$

where:

C is the capacitance of capacitor 94;

E is a predetermined amount of energy required to power a predetermined number of puffs; and

V is a predetermined battery voltage.

The proper resistance of heating element 14 is obtained by dividing the desired time constant (discharge rate of capacitor 94) by the capacitance of capacitor 94.

Referring to FIGS. 9 and 10, battery 96 charges capacitor 94. A control circuit 98 (FIG. 10) typically connects capacitor 94, battery 96, and heating element 14 through a control switch 100. When switch 100 is initially actuated, the switch connects poles b and c, to charge capacitor 94. Switch 100 simultaneously connects poles a and d to connect the battery to heating element 14, through a current or voltage limiting device, to raise the heater temperature. Heating element 14 raises the temperature of flavor-generating medium 12 to a standby, low temperature, not exceeding the preferred temperature for flavor component production.

To puff article 95, the consumer operates switch 100 to disconnect poles a and d, and poles b and c. The switching operation may be initiated automatically during puffing by a pressure or flow sensor that senses the beginning of a puff. Switch 100 then connects poles c and d, to discharge capacitor 94 through heater 14. Article 95 typically is designed such that the capacitor discharge is matched to the electrical requirements of heating element 14, and the desired heating is accomplished without additional control circuitry. However, additional power control or shaping circuitry may be inserted between poles c and d to modify the capacitor discharge characteristics. When capacitor 94 is discharged, poles c and d are disconnected, and poles a and b are again connected to poles d and c, respectively.

The circuit of FIG. 10 may include additional elements, such as resistors, fuses, or switches to modify or control the energy transfers within the circuit. For example, a resistor 102 may be connected in series between battery 95 and pole b, and in parallel with the lead to pole a to modify the capacitor charging characteristics of the circuit. Resistor 102 is selected to increase the time constant of the charging circuit, thereby reducing the charging rate of capacitor 94. A fuse 104 may be disposed between heating element 14 and pole d of switch 100 to ensure that excessive energy levels

are not delivered to the heating element. A user-actuated switch 106 may be connected to battery 95 to prevent inadvertent discharge from the battery.

The delivery of article 95 may be regulated in several ways (in addition to the methods already described). The level of capacitor recharge may be regulated, thereby controlling the energy available to heating element 14. Alternatively, control circuitry may be used to regulate the current or total power flowing to or from the capacitor.

FIG. 11 shows an illustrative embodiment of a device used to charge the battery of power source 16 (e.g., for the article of FIG. 1). The charging device, designated generally by reference numeral 108, includes a battery 110 and a control circuit 112, disposed within case 114. Control circuit 112 regulates the amount of energy delivered from battery 110 to power source 16. Charging device 108 may also include a switch 116 to permit a consumer to manually control the operation of device 108.

A recess 118 may be provided within case 114 to accept a portion of the article (i.e., power source 16) for charging. The edges at the entrance to recess 118 typically are bevelled to facilitate positioning of the article within the passageway. Article 10 must be oriented such that the positive terminal of battery 110 is electrically connected to the positive terminal of power source 16. Recess 118 is provided with means for ensuring proper orientation of the article when the article is placed in the recess for charging. In an illustrative embodiment, visual markings are provided on recess 118 and on the article. When the visual markings are properly aligned, the power source 16 is properly positioned for charging.

Battery 110 of device 108 is electrically connected in series with charging contacts 120 and 122. Contacts 120 and 122 provide a path for electricity to flow to the contacts of power source 16. Battery 110 typically has sufficient capacity to power ten to twenty articles (i.e., battery 110 has sufficient capacity to recharge the battery of power source 16 ten to twenty times) before battery 110 must be recharged or replaced. Battery 110 has a high voltage to facilitate quickly recharging power source 16. Battery 110 typically is a rechargeable lithium or nickel cadmium battery.

When a consumer properly positions the power source portion of the smoking article within device 108, power source 16 will begin to charge. To achieve optimum charging, the charge rate and control circuitry must be tailored to the characteristics of the specific power source being charged. To reduce the waiting period and inconvenience to the consumer, a fast charging rate is desirable. In a preferred embodiment of this invention, battery 110

charges power source 16 at approximately one-third of the capacity rate (i.e., at a rate of 83 milliamps for a 250 mAH battery pack). Charging at this faster rate, or at even faster rates (which are possible with the appropriate control circuit), necessitates the use of control circuitry to prevent overcharging and damaging power source 16.

Control circuit 112 regulates the electrical energy transferred from battery 110 to power source 16. Circuit 112 permits power source 16 (e.g., a nickel cadmium battery) to be charged at a fast rate. Circuit 112 may operate in a variety of ways. In one embodiment, circuit 112 includes a relay which disconnects the power to contacts 120 and 122 when power source 16 has been charged to a predetermined level or switches to a trickle charge to maintain full charge. Power source 16 is charged to a level that is less than maximum capacity, which typically may be approximately 90 percent of capacity. In an alternative embodiment, circuit 112 converts excess electrical energy to heat energy (i.e., circuit 112 functions as a thermal cut-off). Other control circuits suitable for use in this invention are described in Sanyo CADNICA Technical Data Publication, No. SF6235, pp. 35-40, which is hereby incorporated by reference herein.

In an alternative embodiment of the invention, shown in FIG. 12, charging device 108 includes external charging contacts 124 and 126 disposed on the exterior of case 114. Contacts 124 and 126 permit the charging of battery 110 without requiring the battery to be removed from the case. Charging device 108 may also include clip 128 disposed on the exterior surface of case 114. Clip 128 enables the smoker to carry charging device 108 by attaching it, for example, to a pocket, belt, or pocketbook.

In a further embodiment of the invention, article 10 may be charged or powered using an appliance-type power unit 130 shown in FIGS. 13 and 14. Power unit 130 typically may charge a battery or capacitor within the article, or may supply power directly to the article's heating element using appropriate isolation techniques to prevent shock hazard. This could also include techniques for transferring the energy by inductive coupling, or utilizing Curie point control of the temperature reached by the heating element. Power unit 130 may be used, for example, in meeting rooms, on desktops, or wherever portability is not required. Power unit 130 has one or more recesses 132 to receive either power source 16 or connecting pins 30 of the article (FIGS. 1 and 2, respectively). Alternatively, power unit 130 includes conductive wires 134 for electrically connecting smoking articles to the power unit (via connecting pins 30). Wires 134 conduct electricity to the smoking article while the consumer puffs on the article.

A switch 136 on power unit 130 connects and disconnects power to the articles. Power is supplied to power unit 130 via a conventional power cord and plug 138 from a conventional 120-Volt power source. Power unit 130 includes a transformer and conventional voltage regulating circuitry to provide the appropriate voltage and power output to the articles. Power unit 130 may include control circuitry similar to circuit 112, to prevent overcharging the articles in recesses 132.

If desired, the articles of this invention may include means for indicating that flavor-generating medium 12 has reached the end of its useful life and should be replaced. The indicating means may be a color indicator, which changes to a predetermined color to indicate that the device is finished. Alternatively, the indicating means may be a fusible link which melts to disconnect the power to heating element 14 after a predetermined period of operation (preferably corresponding to the useful life of flavor-generating medium 12).

FIG. 15 shows another alternative embodiment of the article of this invention. Smoking article 139 includes a tube 141, attached to a metal canister 143 and filter 28. Metal canister 143, made preferably of aluminum, is filled with flavor-generating medium 12, and is partly closed by a perforated metal clip 140. Tube 141 and canister 143 are cylindrical in shape. The canister is perforated at the distal end 142, allowing air to be drawn through the perforations, into the tube, and out filter 28. The edges of the metal container typically may be beveled to assist the consumer in inserting the article into the heating apparatus of FIG. 16.

Smoking article 139 does not contain a heating element; it is designed to be kept in the heating apparatus of FIG. 16 during operation. Flavor-generating medium 12 is captured within metal canister 143 to facilitate heat transfer between the heating element and the flavor-generating medium.

Tube 141 typically is constructed of thermally insulating rigid material, such as cardboard. The tube typically is foil-lined to prevent flavors from escaping during operation. Space 142 allows the air drawn through the heated flavor-generating medium to cool to an acceptable temperature before entering the consumer's mouth.

FIG. 16 shows an illustrative embodiment of apparatus used to heat the article 139 of FIG. 15. The apparatus includes a case 144 having tubular passageways 146 and 148 through case 144 to create a path for air to flow to article 139. The apparatus also includes a heating element 150, which typically may be hollow and cylindrical in shape. Heating element 150 is a self-regulating, positive temperature coefficient thermistor or a conventional resistive element. A switch 152, mounted on case 144, is provided to selectively

apply electrical energy to heating element 150 from a power source 154. In an alternative embodiment (shown in FIG. 17), switch 152 may be a pressure-activated switch located inside passageway 146 such that heating element 150 is automatically energized by power source 154 when the article is inserted into passageway 146. In yet another embodiment, canister 143 of article 134 provides a conductive path for electrical power to heating element 150 when the article is properly positioned in passageway 146.

When switch 152 is closed, an electrical circuit is formed between power source 154, switch 152, and heating element 150 via electrical conductors 156. Metal canister 143 of article 134 rests in passageway 146, causing canister 143 to contact the inside surface of heating element 150, thereby heating canister 143 and flavor-generating medium 12 to a predetermined temperature. The delivery of article 139 can be regulated by varying the temperature of heating element 150. However, it may be preferable, particularly in embodiments in which the article does not contain a heat source, to regulate flavor strength by varying the quantity or composition of the flavor-generating medium.

Article 139 is received in passageway 146 to be heated, and remains in the passageway throughout operation. Passageway 148, which typically may have a smaller diameter than passageway 146, connects passageway 146 to the outside of case 144. Passageway 148 creates a path for air to be drawn through article 139, and may take any shape or form which accomplishes that result. Passageway 146 and the interior of heating element 150 typically are sized to fit snugly around metal canister 143 for efficient heat transfer, but passageway 146 is preferably slightly different in size than passageway 148, to ensure proper positioning of metal canister 143 against the heating element. The heating device may include a second heating element 156 (FIG. 17) to pre-heat the air as it is drawn through passageway 148. Heating element 156 may be of any desired shape or size, and may be disposed at any convenient point within passageway 148.

It will be understood that the foregoing description is merely illustrative of the principles of the invention, and that various modifications can be made by those skilled in the art without departing from the scope of the invention. For example, article 10 (Fig. 2) could be powered via charging contacts disposed on the outer surface of and extending annularly around heater base 32. Similarly, contacts 120 and 122 of charging device 108 could be replaced with spring clips designed to contact annular charging contacts on the outer surface of article 10.

Claims

1. A smoking article comprises a flavor-generating medium (12), an electrical heating element (14), and electrical energy delivery means (16), the flavor-generating medium being detachable from the electrical heating element, characterised in that the electrical heating element (14) is in thermal contact with the flavor-generating medium, in that the electrical energy delivery means (16) delivers electrical energy to the heating element to cause the heating element to heat the flavor-generating medium to release flavor components therefrom, and by regulating means (46) for regulating the amount of electrical energy delivery by the energy delivery means. 5
10
2. A smoking article according to Claim 1, wherein the regulating means comprises means for applying a predetermined temperature cycle to the heating element. 15
20
3. A smoking article according to Claim 1, wherein the regulating means comprises control means for applying a predetermined voltage cycle to the heating element. 25
4. A smoking article comprising a flavor-generating medium (12), an electrical heating element (14), and electrical energy delivery means (16) for delivering electrical energy to the heating element, characterised in that the electrical heating element is in thermal contact with the flavor-generating medium, in that delivery of electrical energy to the heating element causes the heating element to heat the flavor-generating medium to release flavor components therefrom, and by regulating means (46) for regulating the amount of electrical energy delivered by the electrical energy delivering means including means for applying a predetermined temperature controlling cycle to the flavor-generating medium. 30
35
40
5. A smoking article according to Claim 4, wherein the means for applying a predetermined temperature controlling cycle to the flavor-generating medium comprises means for applying a predetermined temperature cycle to the heating element. 45
50
6. A smoking article according to Claim 4, wherein the means for applying a predetermined temperature controlling cycle to the flavor-generating medium comprises means for applying a predetermined voltage cycle to the heating element. 55
7. A smoking article according to Claim 3 or 6, wherein said control means is an electronic circuit (46) comprising switching means (48) for initiating said predetermined voltage cycle, means (56) for applying a relatively high voltage to said heating element during a first predetermined time interval, and means for inhibiting said means for applying a relatively high voltage from operating during a second predetermined time interval. 5
10
8. A smoking article according to Claim 7, wherein application of said relatively high voltage to said heating element heats said flavor-generating medium to a temperature in the range between the temperature at which flavor components are produced and the combustion temperature of said flavor-generating medium. 15
20
9. A smoking article according to Claim 7 or 8, wherein said first predetermined time interval is between about 0.2 seconds to about 4.0 seconds. 25
10. A smoking article according to Claim 7, 8 or 9, wherein said second predetermined time interval is between about 5 seconds to about 30 seconds. 30
11. A smoking article according to any of Claims 7 to 10, wherein said electronic circuit further comprises means (58) for applying a relatively low voltage to said heating element whenever the means for applying a relatively high voltage is not operating. 35
40
12. A smoking article according to Claim 11, wherein application of said relatively low voltage heats said flavor-generating medium to a temperature above ambient temperature but below the temperature at which said flavor-generating medium generates flavor components. 45
13. A smoking article according to any of Claims 7 to 12, comprising means (54) for indicating that said relatively high voltage is being applied to said heating element. 50
14. A smoking article according to any of Claims 7 to 13, comprising means (52) for indicating that said relatively low voltage is being applied to said heating element. 55
15. A smoking article according to Claim 2 or Claim 5, wherein the temperature cycle applying means comprises means for applying a first predetermined temperature comprising

- means for applying a temperature above the temperature at which flavor components are generated and below the combustion temperature of said flavor-generating medium.
16. A smoking article according to Claim 2 or 5, wherein the temperature cycle applying means comprises means for applying a second predetermined temperature to the heating element comprising means for applying a temperature above ambient temperature and below the temperature at which said flavor-generating medium generates flavor components.
17. A smoking article according to any preceding claim, comprising means (85) for sensing the temperature of the flavor-generating medium, the energy delivering means being responsive to the sensing means to control the heating of the flavor-generating medium.
18. A smoking article according to any preceding claim, wherein the energy delivery means comprises means (110, 130) for storing electrical energy and applying said energy to said heating element such that said heating element has a relatively low temperature, and less energy is applied to said heating element when said heating element has a relatively high temperature, thereby heating said flavor-generating medium and maintaining said flavor-generating medium at a relatively consistent temperature to release flavor components substantially consistently.
19. A smoking article according to any preceding claim, wherein the heating element and the regulating means comprise a positive temperature coefficient thermistor (14).
20. A smoking article according to Claim 19, wherein the electrical energy raises the temperature of said thermistor to its transition temperature.
21. A smoking article according to any preceding claim, wherein the heating element raises the temperature of the flavor-generating medium to a temperature of about 100 °C to about 500 °C.
22. A smoking article according to Claim 21, wherein the heating element raises the temperature of the flavor-generating medium to a temperature of about 120 °C to about 400 °C.
23. A smoking article according to Claim 22, wherein the heating element raises the temperature of the flavor-generating medium to a temperature of about 200 °C to about 350 °C.
24. A smoking article according to any preceding claim, comprising a second heating element (141) for causing heating of the flavor-generating medium.
25. A smoking article according to Claim 24, wherein the second heating element is in thermal contact with the flavor-generating medium.
26. A smoking article according to Claim 25, wherein the second heating element pre-heats air to be drawn over the flavor-generating medium.
27. A smoking article according to any preceding claim, further comprising means (28) for filtering air and released flavor components.
28. A smoking article according to any preceding claim, wherein said flavor-generating medium (12) is a tobacco flavor source.
29. A smoking article according to Claim 26, 27 or 28, wherein said first heating element raises the temperature of said flavor-generating medium to a first predetermined temperature, and the second heating element raises the temperature of said flavor-generating medium to a second predetermined temperature.
30. A smoking article according to Claim 29, wherein said first predetermined temperature is above ambient temperature and below the temperature at which said flavor-generating medium generates flavor components.
31. A smoking article according to Claim 29 or 30, wherein said second predetermined temperature is above the temperature at which said flavor-generating medium generates flavor components and below the combustion temperature of said flavor-generating medium.
32. A smoking article according to Claim 29, 30 or 31, wherein said electrical energy is applied to said first heating element substantially continuously, and said electrical energy is selectively applied to said second heating element.
33. A smoking article according to any preceding claim, comprising means for storing electrical energy for delivery to the heating element.
34. A smoking article according to Claim 33, wherein the storing means comprises a battery (16).

35. A smoking article according to Claim 34, wherein the battery has a rating between about 20 and about 500 milliamp - hours.
36. A smoking article according to Claim 34 or 35, wherein the battery is rechargeable. 5
37. A smoking article according to Claim 33, wherein the storing means comprises a capacitor (72, 84, 94). 10
38. A smoking article according to any preceding claim, wherein the flavor-generating medium and the heating element are disposed within a hollow tube (20) to form a non-combustion heating article. 15
39. A smoking article according to Claim 38, wherein said tube is foil-lined. 20
40. A smoking article according to Claim 38 or 39, dependent upon any of Claims 31 to 37, wherein said storing means forms a part of the article. 25
41. A smoking article according to Claim 40, wherein the storing means is disposed within the hollow tube.
42. A smoking article according to Claim 40 or 41, wherein said tube is separable along its length into a first and a second portion, said first and second portions including said flavor-generating medium and said means for storing electrical energy, respectively. 30
43. A smoking article according to Claim 42, wherein said first portion of said tube is openable to permit said flavor-generating medium to be replaced. 40
44. A smoking article according to Claim 42 or 43, comprising means for thermally insulating at least a portion of said tube. 45
45. A smoking article according to Claim 44, wherein said means for thermally insulating comprises: an overwrap concentrically surrounding at least said portion of said tube; and a layer of air disposed between said tube and said overwrap. 50
46. A smoking article according to Claim 38, further comprising electrical contacts for connecting said heating element to an external power source. 55
47. A smoking article according to any of Claims 38 to 46, further comprising means for indicating that said flavor-generating medium has reached the end of its useful life.
48. A smoking article according to Claim 38 or 47, comprising a fusible link which melts to disconnect electrically said heating element after a predetermined period of operation.
49. A smoking article according to any of Claims 38 to 48, comprising means for retaining said heating element and said flavor-generating medium in said tube while allowing air to pass through said tube in contact with said flavor-generating medium.
50. A smoking article according to Claim 18, further comprising a capacitor (94) disposed within the article, wherein the said means for storing simultaneously charges the capacitor and delivers electrical energy to the heating element to raise the temperature of the heating element to a first predetermined temperature.
51. A smoking article according to Claim 50, wherein the capacitor is selectively discharged to deliver electrical energy to said heating element to raise the temperature of said heating element to a second predetermined temperature.
52. A smoking article according to Claim 51, further comprising means responsive to air passing over the flavor-generating medium for discharging said capacitor.
53. Apparatus for delivering flavor from a flavor-generating medium, comprising a combination of a non-combustible smoking article (139) and a heating apparatus, the smoking article comprising a hollow tube (141), and a flavor-generating medium (12) characterised in that the flavor-generating medium (12) generates flavor components when heated to a predetermined temperature, and by thermally conductive capturing means (143) connected to the hollow tube for capturing the flavor-generating medium while allowing air to pass through the capturing means, and in that the heating apparatus comprises a housing (144) having a recess (146) for receiving the capturing means, a heating element (150) for heating the flavor-generating medium and arranged in thermal contact therewith when the capturing means is arranged in the recess, and means (152, 154) for selectively applying power to the heating element and therethrough to the flavor-generat-

- ing medium thereby to release the flavor components.
54. Apparatus according to Claim 53, wherein the heating element is a thermistor and is a hollow open-ended cylinder. 5
55. A smoking article according to any of claims 1 to 52, or an apparatus according to claim 53 or 54, wherein said means for selectively applying electrical power is a pressure-activated switch (106) which applies electrical power to said heating element. 10
56. A smoking article according to any of claims 1 to 52, or an apparatus according to any of claims 53 to 55, wherein the flavor-generating medium comprises a packed bed of pellets containing flavor components. 15
57. A smoking article according to any of Claims 1 to 52 or an apparatus according to any of claims 53 to 56, wherein the flavor-generating-medium comprises an extruded rod containing flavor components. 20
58. A smoking article according to any of claims 1 to 52, wherein the flavor-generating medium surrounds an external surface of the heating element. 25
59. A smoking article according to any of claims 1 to 52, wherein the heating element surrounds an external surface of the flavor-generating medium. 30
60. A smoking article according to any of claims 1 to 59, or apparatus according to any of claims 53 to 57, the smoking article or apparatus having electrical contacts and means for supplying electrical energy to the contacts, characterised in that said means for supplying electrical energy comprises means for storing electrical energy (110); means (114) for containing said means for storing electrical energy; and means (120, 122) for making electrical contact between said means for storing electrical energy and said electrical contacts. 35
61. Smoking article or apparatus according to Claim 60, further comprising means (112) for controlling the amount of electrical energy delivered. 40
62. Smoking article or apparatus according to Claim 61, wherein said means for controlling prevents overcharging of a battery within said article by converting excess electrical energy 45
- to heat when said battery has been charged to a predetermined level.
63. Smoking article or apparatus according to Claim 62, wherein said means for controlling prevents over-charging of a battery within said article or apparatus by opening the electrical circuit between said means for storing electrical energy and said battery when said battery has been charged to a predetermined level.
64. Smoking article or apparatus according to any of Claims 60 to 63, comprising means for selectively applying power. 50
65. Smoking article or apparatus according to any of Claims 60 to 64, wherein said means for storing electrical energy receives power from a nominal 120 volt power source via a transformer. 55
66. A method of deriving flavor from a flavor-generating smoking article according to any of claims 1 to 52, or 55 to 65 or apparatus according to any of claims 53 to 57, or 60 to 65, characterised by positioning the heating element adjacent the flavor-generating medium, and applying electrical energy to the heating element to raise the temperature thereof and thereby to heat the flavor-generating medium and cause release of flavor components therefrom, the flavor-generating medium being removable from the heating element.
67. A method of deriving flavor from a smoking article according to any of claims 1 to 52, or 55 to 65 or apparatus according to any of claims 53 to 57, or 60 to 65, characterised by positioning the heating element adjacent the flavor-generating medium, and applying electrical energy to the heating element to raise the temperature thereof and thereby to heat the flavor-generating medium and cause release of flavor components therefrom, the application of energy also comprising regulating the amount of energy by applying a predetermined temperature controlling cycle to the heating element.
68. A method according to Claim 66 or 67, further comprising the step of passing air over the heated flavor-generated medium to mix said air with released flavor components and to convey the released flavor components away from said flavor-generating medium with said air.

69. A method according to Claim 68, comprising the steps of: positioning a further heating element in the path of the air to be passed over said flavor-generating mediums, and applying electrical energy to the further heating element thereby to pre-heat air to be passed over said flavor-generating medium. 5
70. A method according to Claim 68 or 69, further comprising the step of filtering the mixture of air and released flavor components. 10
71. A method according to any of Claims 66 to 70, wherein the heating element is a positive temperature coefficient thermistor and the electrical current raises the temperature of said thermistor to its transition temperature. 15
72. A method according to Claim 71, wherein the transition temperature of the thermistor is in the range from about 100 °C to about 500 °C. 20
73. A method according to any of Claims 66 or 72, wherein the flavor-generating medium is a tobacco flavor source. 25
74. A method according to any of Claims 66 to 73, wherein the electrical energy is applied to the heating element according to a predetermined cycle thereby to control the temperature of the flavor-generating medium and the amount of flavor components released therefrom. 30
75. A method according to any of Claims 66 to 74, wherein said step of applying electrical energy comprises the steps of applying electrical energy to the heating element to raise the temperature of the heating element during a first time interval to a first predetermined temperature that is below the temperature required to release flavor components from said flavor-generating medium, and applying electrical energy to raise the temperature of said heating element to a second predetermined temperature during a second predetermined time interval to release the flavor components. 40 45
76. A method according to Claim 75, wherein said second predetermined temperature is a temperature equal to or above the temperature required to release flavor components and below the combustion temperature of said flavor-generating medium. 50
77. A method according to any of Claims 66 to 76, wherein said step of applying electrical energy comprises the steps of: charging an energy storage device with electrical energy at a first

predetermined rate; and discharging said energy from said energy storage device to said heating element at a second predetermined rate to heat said heating element.

78. A method according to any of Claims 66 to 77, wherein the flavor-generating medium is positioned around an external surface of the heating element.
79. A method according to any of Claims 66 to 77, wherein the heating element is positioned around an external surface of the flavor-generating medium.
80. A method according to any of Claims 66 to 79, wherein the flavor-generating medium comprises a packed bed of pellets containing flavor components.
81. A method according to any of Claims 66 to 79, wherein the flavor-generating medium comprises an extruded rod containing flavor components.

Patentansprüche

1. Raucherware, welche ein aromastofferzeugendes Medium (12), ein elektrisches Heizelement (14) und eine elektrische Energieabgabeeinrichtung (16) aufweist, wobei das aromastofferzeugende Medium von dem elektrischen Heizelement lösbar ist, **dadurch gekennzeichnet**, daß das elektrische Heizelement (14) in Wärmekontakt mit dem aromastofferzeugenden Medium ist, daß die elektrische Energieabgabeeinrichtung (16) elektrische Energie an das Heizelement abgibt, um zu bewirken, daß das Heizelement das aromastofferzeugende Medium erwärmt und Aromastoffkomponenten hiervon freigesetzt werden, und daß eine Regeleinrichtung (46) zur Regulierung der Menge der elektrischen Energieabgabe durch die Energieabgabeeinrichtung aufweist.
2. Raucherware nach Anspruch 1, bei der die Regeleinrichtung eine Einrichtung zum Anlegen eines vorbestimmten Temperaturzyklusses an das Heizelement aufweist.
3. Raucherware nach Anspruch 1, bei der die Regeleinrichtung eine Steuereinrichtung zum Anlegen eines vorbestimmten Spannungszyklusses an das Heizelement aufweist.
4. Raucherware welche ein aromastofferzeugendes Medium (12), ein elektrisches Heizelement (14) und eine elektrische Energieeinrichtung

- (16) zur Abgabe von elektrischer Energie an das Heizelement aufweist, **dadurch gekennzeichnet**, daß das elektrische Heizelement in Wärmekontakt mit dem aromastoff erzeugenden Medium ist, daß die Abgabe der elektrischen Energie an das Heizelement bewirkt, daß das Heizelement das aromastoff erzeugende Medium erwärmt und Aromastoffkomponenten hiervon freigesetzt werden, und daß eine Regeleinrichtung (46) für die Regulierung der Menge der durch die elektrische Energieabgabeinrichtung abgegebenen elektrischen Energie vorgesehen ist, welche eine Einrichtung zum Anlegen eines vorbestimmten temperatursteuerbaren Zyklus an das aromastoff erzeugende Medium umfaßt.
- 5
- 10
- 15
- 20
- 25
- 30
- 35
- 40
- 45
- 50
- 55
10. Raucherware nach Anspruch 7, 8 oder 9, bei der das zweite vorbestimmte Zeitintervall zwischen etwa 5 Sekunden und etwa 30 Sekunden liegt.
11. Raucherware nach einem der Ansprüche 7 bis 10, bei der die elektronische Schaltung ferner eine Einrichtung (58) zum Anlegen einer relativ niedrigen Spannung an das Heizelement aufweist, welche immer dann angelegt wird, wenn die Einrichtung zum Anlegen einer relativ hohen Spannung nicht arbeitet.
12. Raucherware nach Anspruch 11, bei der durch das Anlegen der relativ niedrigen Spannung das aromastoff erzeugende Medium auf eine Temperatur über der Umgebungstemperatur, aber unterhalb der Temperatur erwärmt wird, bei der das aromastoff erzeugende Medium Aromastoffkomponenten erzeugt.
13. Raucherware nach einem der Ansprüche 7 bis 12, bei welcher eine Einrichtung (54) zur Anzeige dafür vorgesehen ist, daß die relativ hohe Spannung an das Heizelement angelegt ist.
14. Raucherware nach einem der Ansprüche 7 bis 13, welche eine Einrichtung (52) zur Abgabe aufweist, das die relativ niedrige Spannung an das Heizelement angelegt ist.
15. Raucherware nach Anspruch 2 oder Anspruch 5, bei der die Temperaturzyklus-Anlegeeinrichtung eine Einrichtung zum Anlegen einer ersten vorbestimmten Temperatur aufweist, welche eine Einrichtung zum Anlegen einer Temperatur über der Temperatur, bei der die Aromastoffkomponenten erzeugt werden und unterhalb der Verbrennungstemperatur des aromastoff erzeugenden Mediums aufweist.
16. Raucherware nach Anspruch 2 oder 5, bei der die Temperaturzyklus-Anlegeeinrichtung eine Einrichtung zum Anlegen einer zweiten vorbestimmten Temperatur an das Heizelement aufweist, welche eine Einrichtung zum Anlegen einer Temperatur über der Umgebungstemperatur und unter der Temperatur aufweist, bei der das aromastoff erzeugende Medium Aromastoffkomponenten erzeugt.
17. Raucherware nach einem der vorangehenden Ansprüche, welche eine Einrichtung (85) zum Erfassen der Temperatur des aromastoff erzeugenden Mediums aufweist, und die Energieabgabeinrichtung auf die Erfassungseinrichtung anspricht, um die Erwärmung des aromastoff-

- erzeugenden Mediums zu steuern.
18. Raucherware nach einem der vorangehenden Ansprüche, bei der die Energieabgabeeinrichtung eine Einrichtung (110,1 30) zum Speichern der elektrischen Energie und zum Anlegen der Energie an das Heizelement derart aufweist, daß das Heizelement eine relativ niedrige Temperatur hat, und daß weniger Energie an das Heizelement angelegt wird, wenn das Heizelement eine relativ hohe Temperatur hat, wodurch das aromastoff erzeugende Medium erwärmt und das aromastoff erzeugende Medium auf einer relativ konstanten Temperatur gehalten wird, um die Aromastoffkomponenten im wesentlichen vollständig abzugeben.
19. Raucherware nach einem der vorangehenden Ansprüche, bei der das Heizelement und die Regeleinrichtung einen Thermistor (14) mit positivem Temperaturkoeffizienten aufweisen.
20. Raucherware nach Anspruch 19, bei der die elektrische Energie die Temperatur des Thermistors auf seine (Übergangstemperatur anhebt.
21. Raucherware nach einem der vorangehenden Ansprüche, bei der das Heizelement die Temperatur des aromastoff erzeugenden Mediums auf eine Temperatur zwischen etwa 100 °C und etwa 500 °C anhebt.
22. Raucherware nach Anspruch 21, bei der das Heizelement die Temperatur des aromastoff erzeugenden Mediums auf eine Temperatur zwischen etwa 120 °C und etwa 400 °C anhebt.
23. Raucherware nach Anspruch 22, bei der das Heizelement die Temperatur des aromastoff erzeugenden Mediums auf eine Temperatur zwischen etwa 200 °C und etwa 350 °C anhebt.
24. Raucherware nach einem der vorangehenden Ansprüche, welche ein zweites Heizelement (141) aufweist, welches bewirkt, daß das aromastoff erzeugende Medium erwärmt wird.
25. Raucherware nach Anspruch 24, bei der das zweite Heizelement in Wärmekontakt mit dem aromastoff erzeugenden Medium ist.
26. Raucherware nach Anspruch 25, bei der das zweite Heizelement die über das aromastoff erzeugende Medium anzusaugende Luft vorwärmt.
27. Raucherware nach einem der vorangehenden Ansprüche, welche eine Einrichtung (28) zum Filtern der Luft und der freigesetzten Aromastoffkomponenten aufweist.
28. Raucherware nach einem der vorangehenden Ansprüche, bei der das aromastoff erzeugende Medium (12) eine Tabakaromastoffquelle ist.
29. Raucherware nach Anspruch 26, 27 oder 28, bei der das erste Heizelement die Temperatur des aromastoff erzeugenden Mediums auf eine erste vorbestimmte Temperatur anhebt, und das zweite Heizelement die Temperatur des aromastoff erzeugenden Mediums auf eine zweite vorbestimmte Temperatur anhebt.
30. Raucherware nach Anspruch 29, bei der die erste vorbestimmte Temperatur über der Umgebungstemperatur und unterhalb der Temperatur liegt, bei der das aromastoff erzeugende Medium Aromastoffkomponenten erzeugt.
31. Raucherware nach Anspruch 29 oder 30, bei der die zweite, vorbestimmte Temperatur über der Temperatur liegt, bei der das aromastoff erzeugende Medium Aromastoffkomponenten erzeugt und unterhalb der Verbrennungstemperatur des aromastoff erzeugenden Mediums liegt.
32. Raucherware nach Anspruch 29, 30 oder 31, bei der die elektrische Energie an das erste Heizelement im wesentlichen kontinuierlich angelegt wird, und daß die elektrische Energie selektiv an das zweite Heizelement angelegt wird.
33. Raucherware nach einem der vorangehenden Ansprüche, welche eine Einrichtung zum Speichern der elektrischen Energie zur Abgabe an das Heizelement aufweist.
34. Raucherware nach Anspruch 33, bei der die Speichereinrichtung eine Batterie (16) aufweist.
35. Raucherware nach Anspruch 34, bei der die Batterie einen Nennwert zwischen etwa 20 und etwa 500 Milliampere/Stunden hat.
36. Raucherware nach Anspruch 34 oder 35, bei der die Batterie wiederaufladbar ist.
37. Raucherware nach Anspruch 33, bei der die Speichereinrichtung einen Kondensator (72, 84, 94) aufweist.

38. Raucherware nach einem der vorangehenden Ansprüche, bei der das aromastofferzeugende Medium und das Heizelement in einem hohlen Rohr (20) angeordnet sind, um einen nicht-brennbar erwärmbaren Gegenstand zu bilden. 5
39. Raucherware nach Anspruch 38, bei der das Rohr mit einer Folie überzogen ist.
40. Raucherware nach Anspruch 38 oder 39 in Abhängigkeit von einem der Ansprüche 31 bis 37, bei der die Speichereinrichtung einen Teil des Gegenstands bildet. 10
41. Raucherware nach Anspruch 40, bei der die Speichereinrichtung in dem hohlen Rohr angeordnet ist. 15
42. Raucherware nach Anspruch 40 oder 41, bei der das Rohr entlang der Längserstreckung in einen ersten und einen zweiten Abschnitt unterteilbar ist, wobei der erste und der zweite Abschnitt das aromastofferzeugende Medium und die Einrichtung zum Speichern der elektrischen Energie jeweils umfassen. 20
43. Raucherware nach Anspruch 42, bei der der erste Abschnitt des Rohrs offenbar ist, um einen Zugang zum Auswechseln des aromastofferzeugenden Mediums zu haben. 25
44. Raucherware nach Anspruch 42 oder 43, welcher eine Einrichtung zum thermischen Isolieren wenigstens eines Teils des Rohres aufweist. 30
45. Raucherware nach Anspruch 44, bei der die Einrichtung zum thermischen Isolieren folgendes aufweist: eine Außenumhüllung, welche konzentrisch wenigstens den Teil des Rohrs umgibt; und eine Luftschicht, welche zwischen dem Rohr und der Außenumhüllung angeordnet ist. 35
46. Raucherware nach Anspruch 38, welche ferner elektrische Kontakte zum Verbinden des Heizelements mit einer externen Energiequelle aufweist. 40
47. Raucherware nach einem der Ansprüche 38 bis 46, welche ferner eine Einrichtung zum Abgeben aufweist, daß das aromastofferzeugende Medium das Ende seiner Nutzungszeit erreicht hat. 45
48. Raucherware nach Anspruch 38 oder 47, welche eine schmelzbare Verbindung aufweist, und welche zum Erschmelzen kommt, um das elektrische Heizelement nach einer vorbestimmten Betriebsperiode abzukoppeln. 50
49. Raucherware nach einem der Ansprüche 38 bis 48, welche eine Einrichtung zum Festlegen des Heizelements und des aromastofferzeugenden Mediums in dem Rohr aufweist, während zugleich ermöglicht wird, daß Luft durch das Rohr in Kontakt mit dem aromastofferzeugenden Medium durchgehen kann. 55
50. Raucherware nach Anspruch 18, welche ferner einen Kondensator (94) aufweist, welcher in dem Gegenstand angeordnet ist, bei der die Einrichtung zum Speichern gleichzeitig den Kondensator auflädt und die elektrische Energie an das Heizelement abgibt, um die Temperatur des Heizelements auf eine erste vorbestimmte Temperatur anzuheben.
51. Raucherware nach Anspruch 50, bei der der Kondensator selektiv entladen wird, um elektrische Energie an das Heizelement abzugeben und die Temperatur des Heizelements auf eine zweite vorbestimmte Temperatur anzuheben.
52. Raucherware nach Anspruch 51, welche ferner eine Einrichtung aufweist, die auf die über das aromastofferzeugende Medium gehende Luft zum Entladen des Kondensators anspricht.
53. Vorrichtung zur Abgabe eines Aromastoffs von einem aromastofferzeugenden Medium, welche eine Kombination aus einer nichtbrennbaren Raucherware (139) und einer Heizeinrichtung aufweist, wobei die Raucherware ein hohles Rohr (141) und ein aromastofferzeugendes Medium (12) aufweist, **dadurch gekennzeichnet**, daß das aromastofferzeugende Medium (12) Aromastoffkomponenten erzeugt, wenn eine Erwärmung auf eine vorbestimmte Temperatur erfolgt, daß eine wärmeleitende Auffangeinrichtung (143) mit dem hohlen Rohr zum Auffangen des aromastofferzeugenden Mediums verbunden ist, während zugleich Luft durch die Auffangeinrichtung geben kann, und daß die Heizeinrichtung (144), welches eine Ausnehmung (146) zur Aufnahme der Auffangeinrichtung, ein Heizelement (150) zur Erwärmung des aromastofferzeugenden Mediums, welche in Wärmekontakt hiermit angeordnet ist, wenn die Auffangeinrichtung in der Ausnehmung angeordnet ist, aufweist, und daß Einrichtungen (152, 154) zum selektiven Anlegen von Energie an das Heizelement und hierdurch an das aromastofferzeugende Medium vorgesehen sind, wodurch Aromastoffkomponenten freigesetzt werden.

54. Vorrichtung nach Anspruch 53, bei der das Heizelement ein Thermistor ist und von einem hoben, offenendigen Zylinder gebildet wird.
55. Raucherware nach einem der Ansprüche 1 bis 52, oder eine Vorrichtung nach einem der Ansprüche 53 oder 54, bei denen die Einrichtung zum selektiven Anlegen der elektrischen Energie ein durch Druck aktivierbarer Schalter (106) ist, welcher elektrische Energie an das Heizelement anlegt. 5 10
56. Raucherware nach einem Ansprüche 1 bis 52 oder eine Vorrichtung nach einem der Ansprüche 53 bis 55, bei denen das aromastoff erzeugende Medium ein gepacktes Bett von Pellets aufweist, welche Aromastoffkomponenten enthalten. 15
57. Raucherware nach einem der Ansprüche 1 bis 52 oder eine Vorrichtung nach einem der Ansprüche 53 bis 56, bei denen das aromastoff erzeugende Medium einen extrudierten Stab aufweist, welcher Aromastoffkomponenten enthält. 20 25
58. Raucherware nach einem der Ansprüche 1 bis 52, bei der das aromastoff erzeugende Medium eine Außenfläche des Heizelements umgibt. 30
59. Raucherware nach einem der Ansprüche 1 bis 52, bei der das Heizelement eine Außenfläche des aromastoff erzeugenden Mediums umgibt.
60. Raucherware nach einem der Ansprüche 1 bis 59 oder Vorrichtung nach einem der Ansprüche 53 bis 57, bei denen die Raucherware oder die Vorrichtung elektrische Kontakt und eine Einrichtung zum Zuführen von elektrischer Energie zu den Kontakten aufweist, dadurch gekennzeichnet, daß die Einrichtung zum Zuführen der elektrischen Energie eine Einrichtung zum Speichern von elektrischer Energie (110); eine Einrichtung (114) zur Aufnahme der Einrichtung zum Speichern der elektrischen Energie; und eine Einrichtung (120, 122) zum Herstellen eines elektrischen Kontaktes zwischen der Einrichtung zum Speichern der elektrischen Energie und den elektrischen Kontakten aufweist. 35 40 45 50
61. Raucherware oder Vorrichtung nach Anspruch 60, welche ferner eine Einrichtung (112) zum Steuern der abgegebenen elektrischen Energiemenge aufweist. 55
62. Raucherware oder Vorrichtung nach Anspruch 61, bei der die Einrichtung zum Steuern ein Überladen einer Batterie in dem Gegenstand dadurch verbindet, daß überschüssige elektrische Energie zur Erwärmung umgewandelt wird, wenn die Batterie auf einen vorbestimmten Wert aufgeladen worden ist.
63. Raucherware oder Vorrichtung nach Anspruch 62, bei der die Einrichtung zum Steuern das Überladen einer Batterie in dem Gegenstand oder der Vorrichtung dadurch verbindet, daß die elektrische Schaltung zwischen der Einrichtung zum Speichern der elektrischen Energie und der Batterie geöffnet wird, wenn die Batterie auf einen vorbestimmten Wert aufgeladen ist.
64. Raucherware oder Vorrichtung nach einem der Ansprüche 60 bis 63, welche eine Einrichtung zum selektiven Anlegen von Energie aufweist.
65. Raucherware oder Vorrichtung nach einem der Ansprüche 60 bis 64, bei der die Einrichtung zum Speichern die elektrische Energie von einer Nennspannungsquelle mit 120 Volt über einen Transformator erhält.
66. Verfahren zum Abgeben von Aromastoff von einer aromastoff erzeugenden Raucherware nach einem der Ansprüche 1 bis 52 oder 55 bis 65 oder Vorrichtung nach einem der Ansprüche 53 bis 57 oder 60 bis 65, dadurch gekennzeichnet, daß das Heizelement in der Nähe des aromastoff erzeugenden Mediums angeordnet wird, die elektrische Energie an das Heizelement angelegt wird, um die Temperatur hiervon anzuheben und zu bewirken, daß Aromastoffkomponenten hiervon freigesetzt werden, und daß das aromastoff erzeugende Medium von dem Heizelement abnehmbar ist.
67. Verfahren zum Abgeben von Aromastoffen von einer Raucherware nach einem der Ansprüche 1 bis 52 oder 55 bis 65 oder einer Vorrichtung nach einem der Ansprüche 53 bis 57 oder 60 bis 65, dadurch gekennzeichnet, daß das Heizelement in der Nähe des aromastoff erzeugenden Mediums angeordnet wird, und daß elektrische Energie an das Heizelement angelegt wird, um die Temperatur desselben anzuheben und hierdurch das aromastoff erzeugende Medium zu erwärmen und zu bewirken, daß Aromastoffkomponenten hiervon freigesetzt werden, wobei bei dem Anlegen der Energie auch eine Regelung der Energiemenge dadurch erfolgt, daß ein vorbestimmter Temperatursteuerzyklus an das Heizelement angelegt wird.

68. Verfahren nach Anspruch 66 oder 67, welches ferner den Schritt aufweist, gemäß dem Luft über das erwärmte aromastoffzeugende Medium streichen kann, um die Luft mit den freigesetzten Aromastoffkomponenten zu vermischen und die freigesetzten Aromastoffkomponenten von dem aromastoffzeugenden Medium mit der Luft wegzubefördern. 5
69. Verfahren nach Anspruch 68, welches die folgenden Schritte aufweist: Anordnen eines weiteren Heizelements auf dem Strömungsweg der Luft, welche die aromastoffzeugenden Medien überstreicht, und Anlegen von elektrischer Energie an das weitere Heizelement, wodurch die vorgewärmte Luft über das aromastoffzeugende Medium geleitet wird. 10
70. Verfahren nach Anspruch 68 oder 69, welches ferner den Schritt aufweist, gemäß dem das Gemisch aus Luft und freigesetzten Aromastoffkomponenten gefiltert wird. 20
71. Verfahren nach einem der Ansprüche 66 bis 70, bei dem das Heizelement ein Thermistor mit positivem Temperaturkoeffizient ist, und der elektrische Strom die Temperatur des Thermistors auf die Übergangstemperatur anhebt. 25
72. Verfahren nach Anspruch 71, bei dem die Übergangstemperatur des Thermistors in einem Bereich von etwa 100 °C bis etwa 500 °C liegt. 30
73. Verfahren nach einem der Ansprüche 66 oder 72, bei dem das aromastoffzeugende Medium eine Tabakaromastoffquelle ist. 35
74. Verfahren nach einem der Ansprüche 66 bis 73, bei dem die elektrische Energie an das Heizelement nach Maßgabe eines vorbestimmten Zyklusses angelegt wird, wodurch die Temperatur des aromastoffzeugenden Mediums und die Menge der hiervon freigesetzten Aromastoffkomponenten gesteuert werden. 40
75. Verfahren nach einem der Ansprüche 6 bis 74, bei dem der Schritt zum Anlegen der elektrischen Energie die Schritte aufweist, gemäß denen die elektrische Energie an das Heizelement angelegt wird, um die Temperatur des Heizelements während eines ersten Zeitintervalls auf eine erste vorbestimmte Temperatur zu erwärmen, die niedriger als die Temperatur ist, welche erforderlich ist, um Aromastoffkomponenten von dem aromastoffzeugenden Medium freizusetzen, und Anlegen der elektrischen Energie zum Anheben der Temperatur des Heizelements auf eine zweite vorbestimmte Temperatur während eines vorbestimmten zweiten Zeitintervalls, um Aromastoffkomponenten freizusetzen. 45
76. Verfahren nach Anspruch 75, bei dem die zweite vorbestimmte Temperatur eine Temperatur gleich oder größer der Temperatur ist, welche erforderlich ist, um Aromastoffkomponenten freizusetzen und die niedriger als die Verbrennungstemperatur des aromastoffzeugenden Mediums ist. 50
77. Verfahren nach einem der Ansprüche 66 bis 76, bei dem der Schritt zum Anlegen der elektrischen Energie die folgenden Schritte aufweist: Aufladen einer Energiespeichereinrichtung mit elektrischer Energie bei einer ersten vorbestimmten Rate; und Abgeben der Energie von der Energiespeichereinrichtung an das Heizelement mit einer zweiten vorbestimmten Rate, um das Heizelement zu erwärmen. 55
78. Verfahren nach einem der Ansprüche 66 bis 77, bei dem das aromastoffzeugende Medium um eine Außenfläche des Heizelements angeordnet wird. 60
79. Verfahren nach einem der Ansprüche 66 bis 77, bei dem das Heizelement um eine Außenfläche des aromastoffzeugenden Mediums angeordnet wird. 65
80. Verfahren nach einem der Ansprüche 66 bis 79, bei dem das aromastoffzeugende Medium ein gepacktes Bett von Pellets aufweist, welche Aromastoffkomponenten enthalten. 70
81. Verfahren nach einem der Ansprüche 66 bis 79, bei dem das aromastoffzeugende Medium einen extrudierten Stab aufweist, welcher Aromastoffkomponenten enthält. 75
- 45 **Revendications**
1. Article à fumer comprenant un milieu générateur d'arôme (12), un élément chauffant électrique (14), et des moyens (16) fournisseurs d'énergie électrique, le milieu générateur d'arôme pouvant être détaché de l'élément chauffant électrique (14), caractérisé en ce que l'élément chauffant électrique (14) est en contact thermique avec le milieu générateur d'arôme, en ce que les moyens (16) fournisseurs d'énergie électrique fournissent de l'énergie électrique à l'élément chauffant pour amener l'élément chauffant à chauffer le milieu

- générateur d'arôme pour en dégager les composants d'arôme, et par des moyens de régulation (46) servant à régler la quantité d'énergie électrique par les moyens fournisseurs d'énergie.
2. Article à fumer selon la revendication 2, dans lequel les moyens de régulation comprennent des moyens servant à appliquer un cycle de température prédéterminé à l'élément chauffant.
3. Article à fumer selon la revendication 1, dans lequel les moyens de régulation comprennent des moyens de commande servant appliquer un cycle de tension prédéterminé à l'élément chauffant.
4. Article à fumer comprenant un milieu générateur d'arôme (12), un élément chauffant électrique (14) et des moyens (16) à énergie électrique servant à fournir de l'énergie électrique à l'élément chauffant, caractérisé en ce que l'élément chauffant électrique est en contact thermique avec le milieu générateur d'arôme, en ce que la fourniture d'énergie électrique à l'élément chauffant amène l'élément chauffant à chauffer le milieu générateur d'arôme pour en dégager les composants d'arôme, et par des moyens de régulation (46) servant à régler la quantité d'énergie électrique fournie par les moyens fournisseurs d'énergie électrique qui comprennent des moyens servant à appliquer un cycle de commande de température prédéterminé au milieu générateur d'arôme.
5. Article à fumer selon la revendication 4, dans lequel les moyens servant à appliquer un cycle de commande de température prédéterminé au milieu générateur d'arôme comprennent des moyens servant à appliquer un cycle de température prédéterminé à l'élément chauffant.
6. Article à fumer selon la revendication 4, dans lequel les moyens servant à appliquer un cycle de commande de température prédéterminé au milieu générateur d'arôme comprennent des moyens servant à appliquer un cycle de tension prédéterminé à l'élément chauffant.
7. Article à fumer selon la revendication 3 ou 6, dans lequel lesdits moyens de commande sont un circuit électronique (46) comprenant des moyens de commutation (48) servant à déclencher ledit cycle de tension prédéterminé, des moyens (56) servant à appliquer une tension relativement élevée audit élément chauffant pendant un premier intervalle de temps prédéterminé, et des moyens servant à empêcher lesdits moyens servant à appliquer une tension relativement élevée de travailler pendant un deuxième intervalle de temps prédéterminé.
8. Article à fumer selon la revendication 7, dans lequel l'application de ladite tension relativement élevée dudit élément chauffant chauffe ledit milieu générateur d'arôme à une température de l'intervalle entre la température à laquelle les composants d'arôme sont produits et la température de combustion dudit milieu générateur d'arôme.
9. Article à fumer selon la revendication 7 ou 8, dans lequel ledit premier intervalle de temps prédéterminé est d'entre environ 0,2 et environ 4,0 secondes.
10. Article à fumer selon la revendication 7, 8 ou 9, dans lequel ledit deuxième intervalle de temps prédéterminé est d'entre environ 5 secondes et environ 30 secondes.
11. Article à fumer selon une quelconque des revendications 7 à 10, dans lequel ledit circuit électronique comprend en outre des moyens (58) servant à appliquer une tension relativement basse audit élément chauffant chaque fois que les moyens servant à appliquer une tension relativement élevée ne sont pas en fonctionnement.
12. Article à fumer selon la revendication 11, dans lequel l'application de ladite tension relativement basse chauffe ledit milieu générateur d'arôme à une température supérieure à la température ambiante mais inférieure à la température à laquelle ledit milieu générateur d'arôme engendre des composants d'arôme.
13. Article à fumer selon une quelconque des revendications 7 à 12, comprenant des moyens (54) servant à indiquer que ladite tension relativement élevée est en cours d'application audit élément chauffant.
14. Article à fumer selon une quelconque des revendications 7 à 13, comprenant des moyens (52) servant à indiquer que ladite tension relativement basse est en cours d'application audit élément chauffant.
15. Article à fumer selon la revendication 2 ou la revendication 5, dans lequel les moyens d'application du cycle de température comprennent

- des moyens servant à appliquer une première température prédéterminée, qui comprennent des moyens servant à appliquer une température supérieure à la température à laquelle les éléments d'arôme sont engendrés et inférieure à la température de combustion dudit milieu générateur d'arôme.
16. Article à fumer selon la revendication 2 ou 5, dans lequel les moyens d'application du cycle de température comprennent des moyens servant à appliquer une deuxième température prédéterminée à l'élément chauffant, qui comprennent des moyens servant à appliquer une température supérieure à la température ambiante et inférieure à la température à laquelle ledit milieu générateur d'arôme engendre les composants d'arôme.
17. Article à fumer selon une quelconque des revendications précédentes, comprenant des moyens (85) servant à capter la température du milieu générateur d'arôme, les moyens fournisseurs d'énergie répondant auxdits moyens capteurs en commandant le chauffage du milieu générateur d'arôme.
18. Article à fumer selon une quelconque des revendications précédentes, dans lequel les moyens fournisseurs d'énergie comprennent des moyens (110, 130) servant à accumuler de l'énergie électrique et à appliquer ladite énergie audit élément chauffant de telle manière que ledit élément chauffant ait une température relativement basse, et une petite quantité d'énergie est appliquée audit élément chauffant lorsque ledit élément chauffant a une température relativement élevée, en chauffant ainsi ledit milieu générateur d'arôme et en maintenant ledit milieu générateur d'arôme à une température relativement constante pour dégager les composants d'arôme de façon à peu près constante.
19. Article à fumer selon une quelconque des revendications précédentes, dans lequel l'élément chauffant et les moyens de régulation comprennent une thermistance (14) à coefficient de température positif.
20. Article à fumer selon la revendication 19, dans lequel l'énergie électrique élève la température de ladite thermistance à sa température de transition.
21. Article à fumer selon une quelconque des revendications précédentes, dans lequel l'élément chauffant élève la température du milieu générateur d'arôme à une température d'entre environ 100 °C et environ 500 °C.
22. Article à fumer selon la revendication 21, dans lequel l'élément chauffant élève la température du milieu générateur d'arôme à une température d'entre environ 120 °C et environ 400 °C.
23. Article à fumer selon la revendication 22, dans lequel l'élément chauffant élève la température du milieu générateur d'arôme à une température d'entre environ 200 °C et environ 350 °C.
24. Article à fumer selon une quelconque des revendications précédentes, comprenant un deuxième élément chauffant (141) servant à provoquer l'échauffement du milieu générateur d'arôme.
25. Article à fumer selon la revendication 24, dans lequel le deuxième élément chauffant est en contact thermique avec le milieu générateur d'arôme.
26. Article à fumer selon la revendication 25, dans lequel le deuxième élément chauffant préchauffe l'air qui sera aspiré en passant sur le milieu générateur d'arôme.
27. Article à fumer selon une quelconque des revendications précédentes, comprenant en outre des moyens (28) servant à filtrer l'air et les composants d'arôme dégagés.
28. Article à fumer selon une quelconque des revendications précédentes, dans lequel ledit milieu générateur d'arôme (12) est une source d'arôme de tabac.
29. Article à fumer selon la revendication 26, 27 ou 28, dans lequel ledit premier élément chauffant élève la température dudit milieu générateur d'arôme à une première température prédéterminée, et le deuxième élément chauffant élève la température dudit milieu générateur d'arôme à une deuxième température prédéterminée.
30. Article à fumer selon la revendication 29, dans lequel ladite première température prédéterminée est supérieure à la température ambiante et inférieure à la température à laquelle ledit milieu générateur d'arôme engendre les composants d'arôme.
31. Article à fumer selon la revendication 29 ou 30, dans lequel ladite deuxième température prédéterminée est supérieure à la température

- à laquelle le milieu générateur d'arôme engendre des composants d'arôme et inférieure à la température de combustion dudit milieu générateur d'arôme.
32. Article à fumer selon la revendication 29, 30 ou 31, dans lequel ladite énergie électrique est appliquée audit premier élément chauffant de façon à peu près continue, et ladite énergie électrique est sélectivement appliquée audit deuxième élément chauffant.
33. Article à fumer selon une quelconque des revendications précédentes, comprenant des moyens servant à accumuler l'énergie électrique pour la fournir à l'élément chauffant.
34. Article à fumer selon la revendication 33, dans lequel les moyens d'accumulation comprennent une pile (16).
35. Article à fumer selon la revendication 34, dans lequel la pile a une capacité d'environ 20 à environ 500 milliampères-heure.
36. Article à fumer selon la revendication 34 ou 35, dans lequel la pile est rechargeable.
37. Article à fumer selon la revendication 33, dans lequel les moyens d'accumulation comprennent un condensateur (72, 84, 94).
38. Article à fumer selon une quelconque des revendications précédentes, dans lequel le milieu générateur d'arôme et l'élément chauffant sont disposés dans un tube creux (20) pour former un article chauffant sans combustion.
39. Article à fumer selon la revendication 38, dans lequel ledit tube est doublé d'une pellicule.
40. Article à fumer selon la revendication 38 ou 39, rattachée à l'une quelconque des revendications 31 à 37, dans lequel lesdits moyens d'accumulation font partie de l'article.
41. Article à fumer selon la revendication 40, dans lequel les moyens d'accumulation sont disposés dans le tube creux.
42. Article à fumer selon la revendication 40 ou 41, dans lequel ledit tube peut être divisé selon sa longueur en une première partie et une deuxième partie, lesdites première et deuxième parties comprenant respectivement le milieu générateur d'arôme et lesdits moyens servant à accumuler l'énergie électrique.
43. Article à fumer selon la revendication 42, dans lequel ladite première partie du tube peut s'ouvrir pour permettre de remplacer ledit milieu générateur d'arôme.
44. Article à fumer selon la revendication 42 ou 43, comprenant des moyens pour isoler thermiquement au moins une partie dudit tube.
45. Article à fumer selon la revendication 44, dans lequel lesdits moyens d'isolation thermique comprennent : un enveloppement qui entoure concentriquement au moins ladite partie dudit tube ; et une couche d'air interposée entre ledit tube et ledit enveloppement.
46. Article à fumer selon la revendication 38, comprenant en outre des contacts électriques servant à connecter ledit élément chauffant à une source d'énergie extérieure.
47. Article à fumer selon une quelconque des revendications 38 à 46, comprenant en outre des moyens servant à indiquer que ledit milieu générateur d'arôme a atteint la fin de sa vie utile.
48. Article à fumer selon la revendication 38 ou 47, comprenant un maillon fusible qui fond pour déconnecter électriquement ledit élément chauffant après une période de fonctionnement prédéterminée.
49. Article à fumer selon une quelconque des revendications 38 à 48, comprenant des moyens servant à retenir ledit élément chauffant et ledit milieu générateur d'arôme dans ledit tube tout en laissant l'air passer dans ledit tube en contact avec ledit milieu générateur d'arôme.
50. Article à fumer selon la revendication 18, comprenant un condensateur (94) disposé à l'intérieur de l'article, dans lequel lesdits moyens servant à accumuler chargent le condensateur et, en même temps, fournissent l'énergie électrique à l'élément chauffant pour élever la température de l'élément chauffant à une première température prédéterminée.
51. Article à fumer selon la revendication 50, dans lequel le condensateur est sélectivement déchargé pour fournir de l'énergie électrique audit élément chauffant pour élever la température dudit élément chauffant à une deuxième température prédéterminée.
52. Article à fumer selon la revendication 51, comprenant en outre des moyens qui répondent au

- passage de l'air sur le milieu générateur d'arôme en déchargeant ledit condensateur.
53. Dispositif pour fournir une arôme à partir d'un milieu générateur d'arôme, comprenant une combinaison d'un article à fumer non combustible (139) et d'un dispositif de chauffage, l'article à fumer comprenant un tube creux (141) et un milieu générateur d'arôme (12), caractérisé en ce que le milieu générateur d'arôme (12) engendre des composants d'arôme lorsqu'il est chauffé à une température prédéterminée, et par des moyens de retenue (143), thermiquement conducteurs, reliés au tube creux pour retenir le milieu générateur d'arôme tout en laissant passer l'air à travers les moyens de retenue, et en ce que le dispositif de chauffage comprend un boîtier (144) ayant une cavité (146) pour recevoir les moyens de retenue, un élément chauffant (150) servant à chauffer le milieu générateur d'arôme et disposé en contact thermique avec ce milieu lorsque les moyens de retenue sont disposés dans la cavité, et des moyens (152, 154) servant à appliquer sélectivement l'énergie à l'élément chauffant et, à travers ce dernier, au milieu générateur d'arôme, pour dégager les composants d'arôme.
54. Dispositif selon la revendication 53, dans lequel l'élément chauffant est une thermistance et est un cylindre creux à extrémité ouverte.
55. Article à fumer selon une quelconque des revendications 1 à 52, ou dispositif selon la revendication 53 ou 54, dans lequel lesdits moyens servant à appliquer sélectivement la puissance électrique sont un commutateur (106) actionné par une pression qui applique la puissance électrique audit élément chauffant.
56. Article à fumer selon une quelconque des revendications 1 à 52, ou dispositif selon une quelconque des revendications 53 à 55, dans lequel le milieu générateur d'arôme comprend une couche tassée de granulés contenant des composants d'arôme.
57. Article à fumer selon une quelconque des revendications 1 à 52, ou dispositif selon une quelconque des revendications 53 à 56, dans lequel le milieu générateur d'arôme comprend une tige extrudée contenant des composants d'arôme.
58. Article à fumer selon une quelconque des revendications 1 à 52, dans lequel le milieu générateur d'arôme entoure une surface externe de l'élément chauffant.
59. Article à fumer selon une quelconque des revendications 1 à 52, dans lequel l'élément chauffant entoure une surface externe du milieu générateur d'arôme.
60. Article à fumer selon une quelconque des revendications 1 à 59, ou dispositif selon une quelconque des revendications 53 à 57, l'article à fumer ou le dispositif ayant des contacts électriques et des moyens servant à appliquer de l'énergie électrique aux contacts, caractérisé en ce que lesdits moyens servant à fournir l'énergie électrique comprennent des moyens servant à accumuler de l'énergie électrique (110) ; des moyens (114) servant à contenir lesdits moyens servant à accumuler l'énergie électrique, et des moyens (120, 122) servant à établir le contact électrique entre lesdits moyens servant à accumuler l'énergie électrique et lesdits contacts électriques.
61. Article à fumer ou dispositif selon la revendication 60, comprenant en outre des moyens (112) servant à commander la quantité d'énergie électrique fournie.
62. Article à fumer ou dispositif selon la revendication 61, dans lequel lesdits moyens servant à commander empêchent de surcharger une pile contenue dans ledit article en transformant l'énergie électrique en excès en chaleur lorsque ladite pile a été chargée à un niveau prédéterminé.
63. Article à fumer ou dispositif selon la revendication 62, dans lequel lesdits moyens servant à commander empêchent de surcharger une pile contenue à l'intérieur dudit article ou dispositif en ouvrant le circuit électrique entre lesdits moyens servant à accumuler l'énergie électrique et ladite pile lorsque ladite pile a été chargée à un niveau prédéterminé.
64. Article à fumer ou dispositif selon une quelconque des revendications 60 à 63, comprenant des moyens servant à appliquer sélectivement l'énergie.
65. Article à fumer ou dispositif selon une quelconque des revendications 60 à 64, dans lequel lesdits moyens servant à accumuler de l'énergie électrique reçoivent leur alimentation d'une source d'alimentation d'une tension nominale de 120 volts à travers un transformateur.

66. Procédé pour dégager un arôme d'un article à fumer générateur d'arôme selon une quelconque des revendications 1 à 52, ou 55 à 65, ou d'un dispositif selon une quelconque des revendications 53 à 57, ou 60 à 65, caractérisé en ce qu'on positionne l'élément chauffant adjacent au milieu générateur d'arôme et on applique de l'énergie électrique à l'élément chauffant pour élever sa température et, de cette façon, chauffer le milieu générateur d'arôme et provoquer le dégagement des composants d'arôme de ce milieu, le milieu générateur d'arôme pouvant être séparé de l'élément chauffant.
67. Procédé pour extraire un arôme d'un article à fumer selon une quelconque des revendications 1 à 52, ou 55 à 65 ou d'un dispositif selon une quelconque des revendications 53 à 57 ou 60 à 65, caractérisé en ce qu'on positionne l'élément chauffant adjacent au milieu générateur d'arôme et on applique de l'énergie électrique à l'élément chauffant pour élever sa température et, de cette façon, chauffer le milieu générateur d'arôme et provoquer le dégagement de composants d'arôme de ce milieu, l'application d'énergie comprenant aussi la régulation de la quantité d'énergie par application d'un cycle de commande de température prédéterminé à l'élément chauffant.
68. Procédé selon la revendication 66 ou 67, comprenant en outre la phase consistant à faire passer de l'air sur le milieu générateur d'arôme chauffé, pour mélanger ledit air aux composants d'arôme dégagés et pour transporter les composants d'arôme dégagés dudit milieu générateur d'arôme avec ledit air.
69. Procédé selon la revendication 68, comprenant les phases consistant à : positionner un autre élément chauffant sur le trajet de l'air qu'il s'agit de faire passer sur ledit milieu générateur d'arôme, et à appliquer de l'énergie électrique audit autre élément chauffant pour préchauffer ainsi l'air qu'il s'agit de faire passer sur ledit milieu générateur d'arôme.
70. Procédé selon la revendication 68 ou 69, comprenant en outre la phase consistant à filtrer le mélange d'air et de composants d'arôme dégagés.
71. Procédé selon une quelconque des revendications 66 à 70, dans lequel l'élément chauffant est une thermistance à coefficient de température positif, et le courant électrique élève la température de ladite thermistance à sa température de transition.
72. Procédé selon la revendication 71, dans lequel la température de transition de la thermistance est dans l'intervalle d'environ 100 °C à environ 500 °C.
73. Procédé selon une quelconque des revendications 66 ou 72, dans lequel le milieu générateur d'arôme est une source d'arôme de tabac.
74. Procédé selon une quelconque des revendications 66 à 73, dans lequel l'énergie électrique est appliquée à l'élément chauffant conformément à un cycle prédéterminé, pour commander ainsi la température du milieu générateur d'arôme et la quantité de composants d'arôme qui s'en dégagent.
75. Procédé selon une quelconque des revendications 66 à 74, dans lequel ladite phase d'application de l'énergie électrique comprend les phases consistant à appliquer de l'énergie électrique à l'élément chauffant pour élever la température de l'élément chauffant pendant un premier intervalle de temps à une première température prédéterminée qui est inférieure à la température nécessaire pour dégager les composants d'arôme dudit milieu générateur d'arôme, et à appliquer de l'énergie électrique pour élever la température dudit élément chauffant à une deuxième température prédéterminée pendant un deuxième intervalle de temps prédéterminé pour dégager les composants d'arôme.
76. Procédé selon la revendication 75, dans lequel ladite deuxième température prédéterminée est une température égale ou supérieure à la température nécessaire pour dégager les composants d'arôme et inférieure à la température de combustion dudit milieu générateur d'arôme.
77. Procédé selon une quelconque des revendications 66 à 76, dans lequel ladite phase d'application d'énergie électrique comprend les phases consistant à charger un dispositif d'accumulation d'énergie avec de l'énergie électrique à un premier taux prédéterminé ; et à décharger ladite énergie dudit dispositif d'accumulation d'énergie dans ledit élément chauffant à un deuxième taux prédéterminé pour chauffer ledit élément chauffant.
78. Procédé selon une quelconque des revendications 66 à 77, dans lequel le milieu générateur

d'arôme est positionné autour d'une surface externe de l'élément chauffant.

79. Procédé selon une quelconque des revendications 66 à 77, dans lequel l'élément chauffant est positionné autour d'une surface externe du milieu générateur d'arôme. 5
80. Procédé selon une quelconque des revendications 66 à 79, dans lequel le milieu générateur d'arôme comprend une couche tassée de granulés contenant des composants d'arôme. 10
81. Procédé selon une quelconque des revendications 66 à 79, dans lequel le milieu générateur d'arôme comprenant une tige extrudée contenant des composants d'arôme. 15

20

25

30

35

40

45

50

55

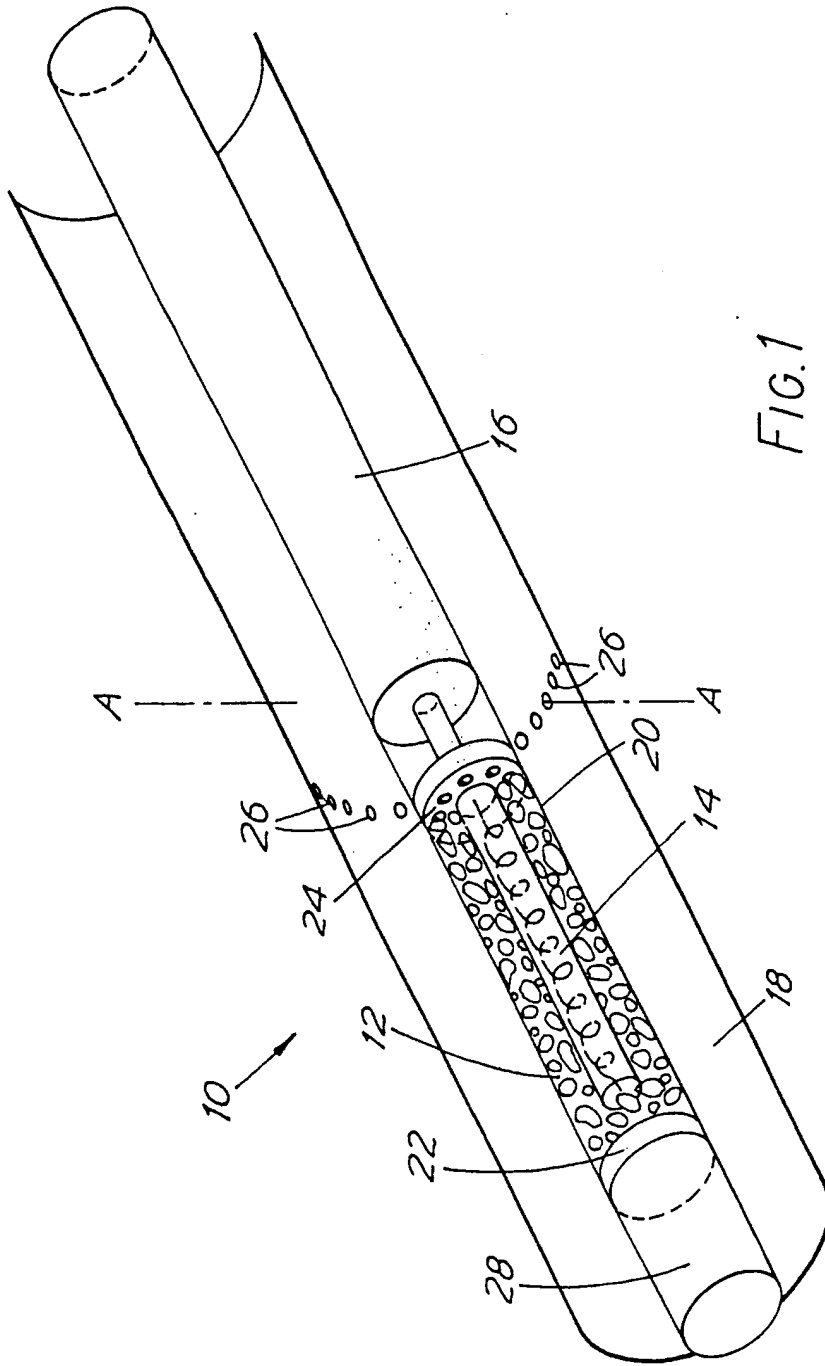

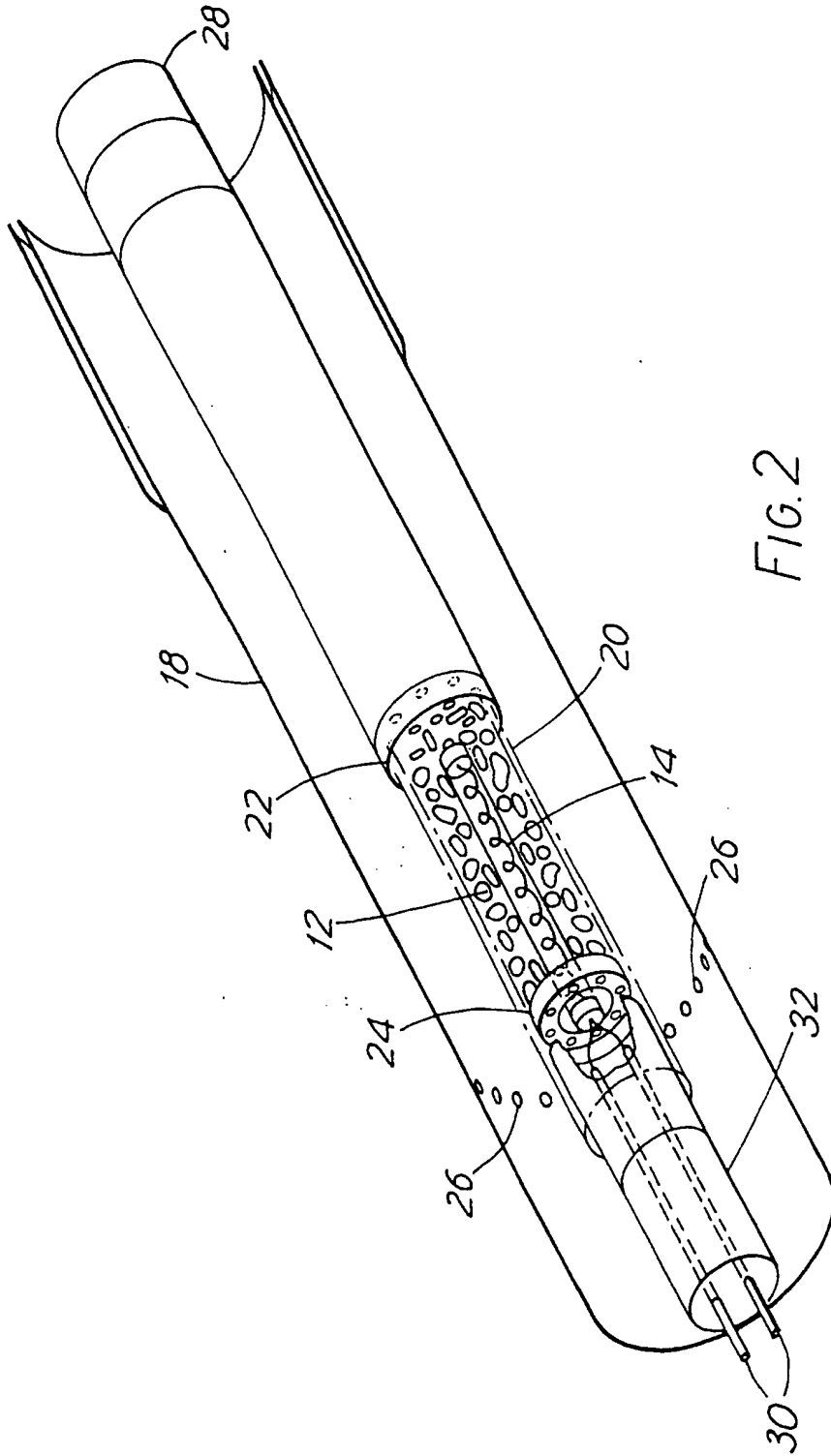

FIG. 2

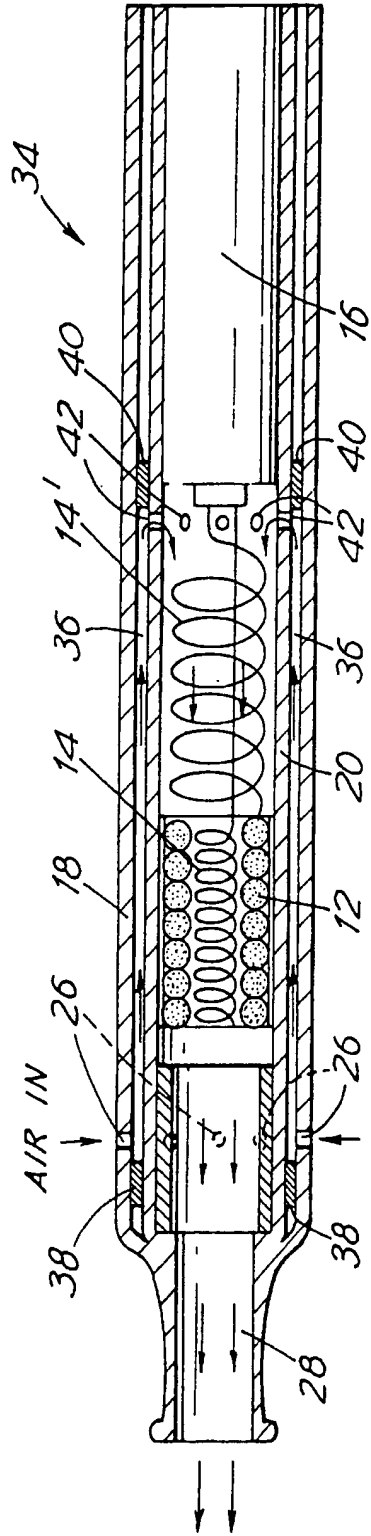

FIG. 3

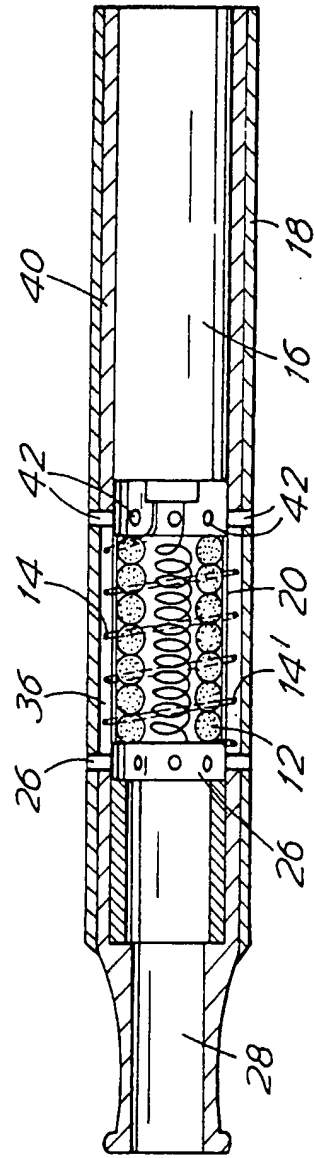
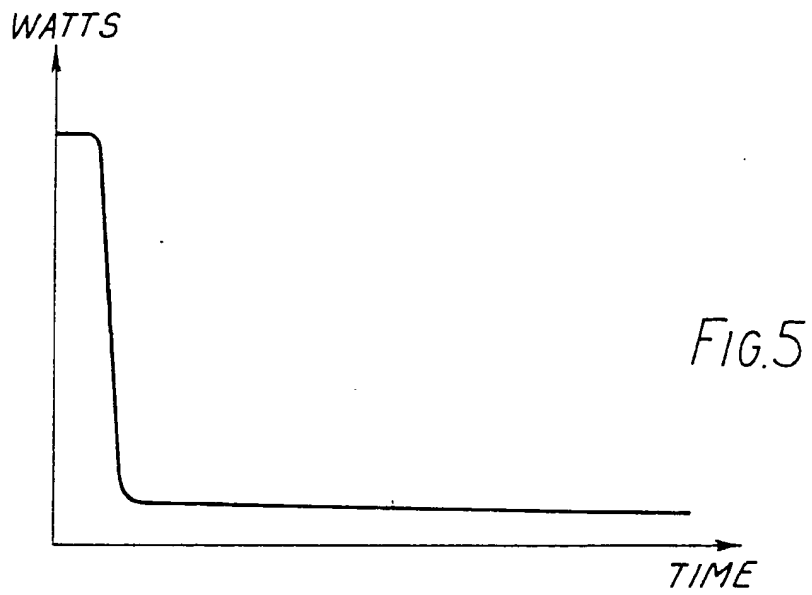
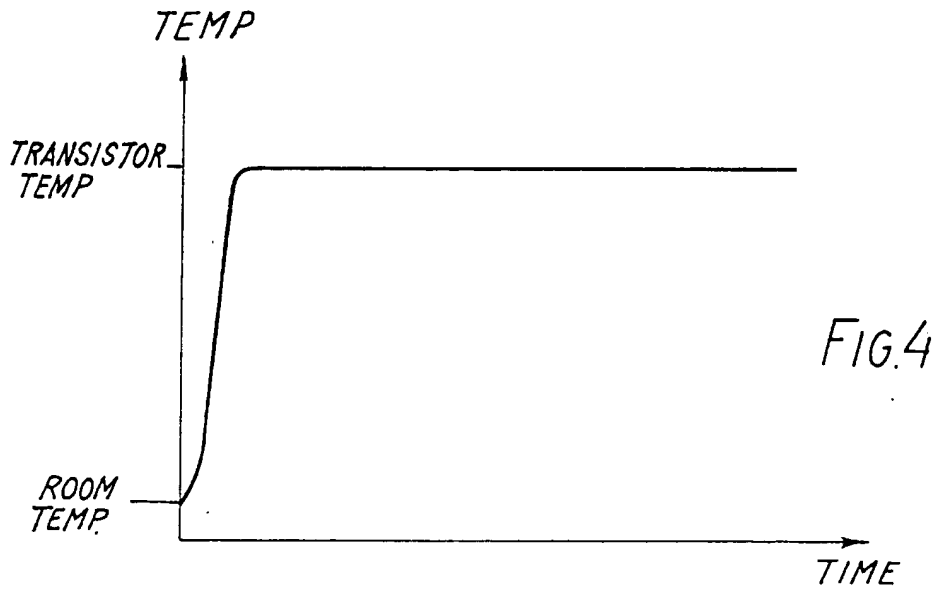

FIG. 6



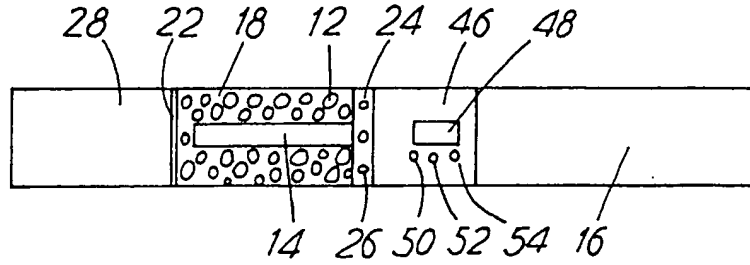

FIG.7

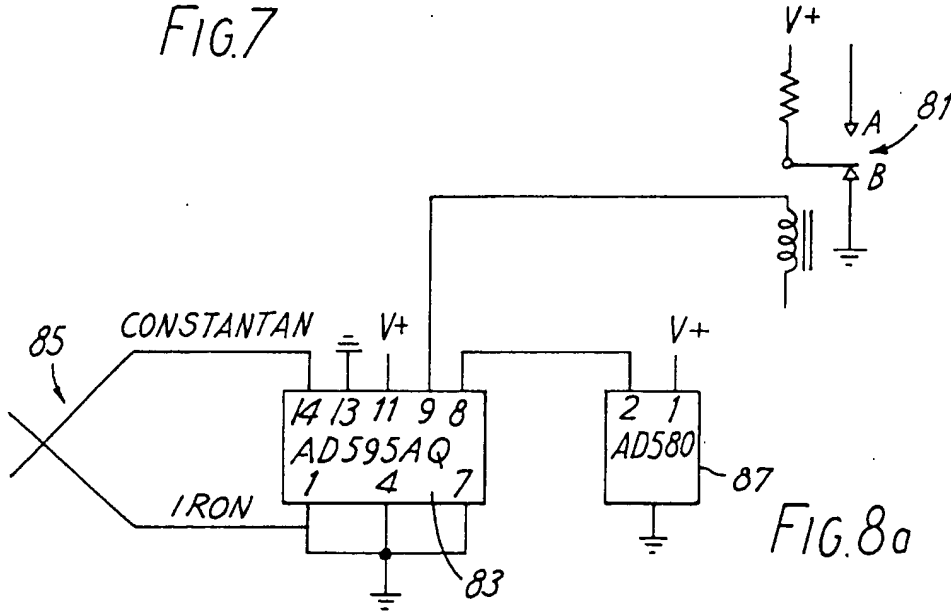

FIG.8a

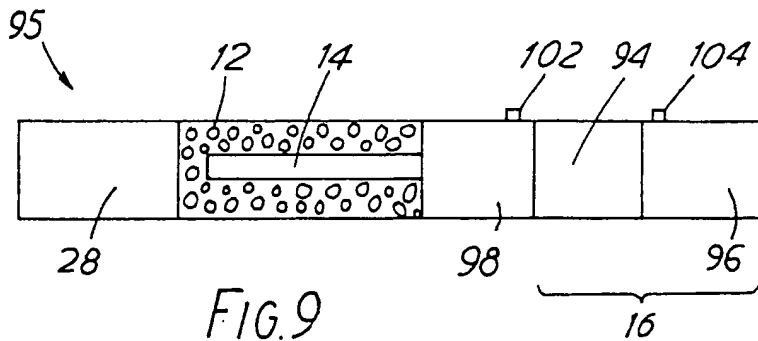

FIG.9

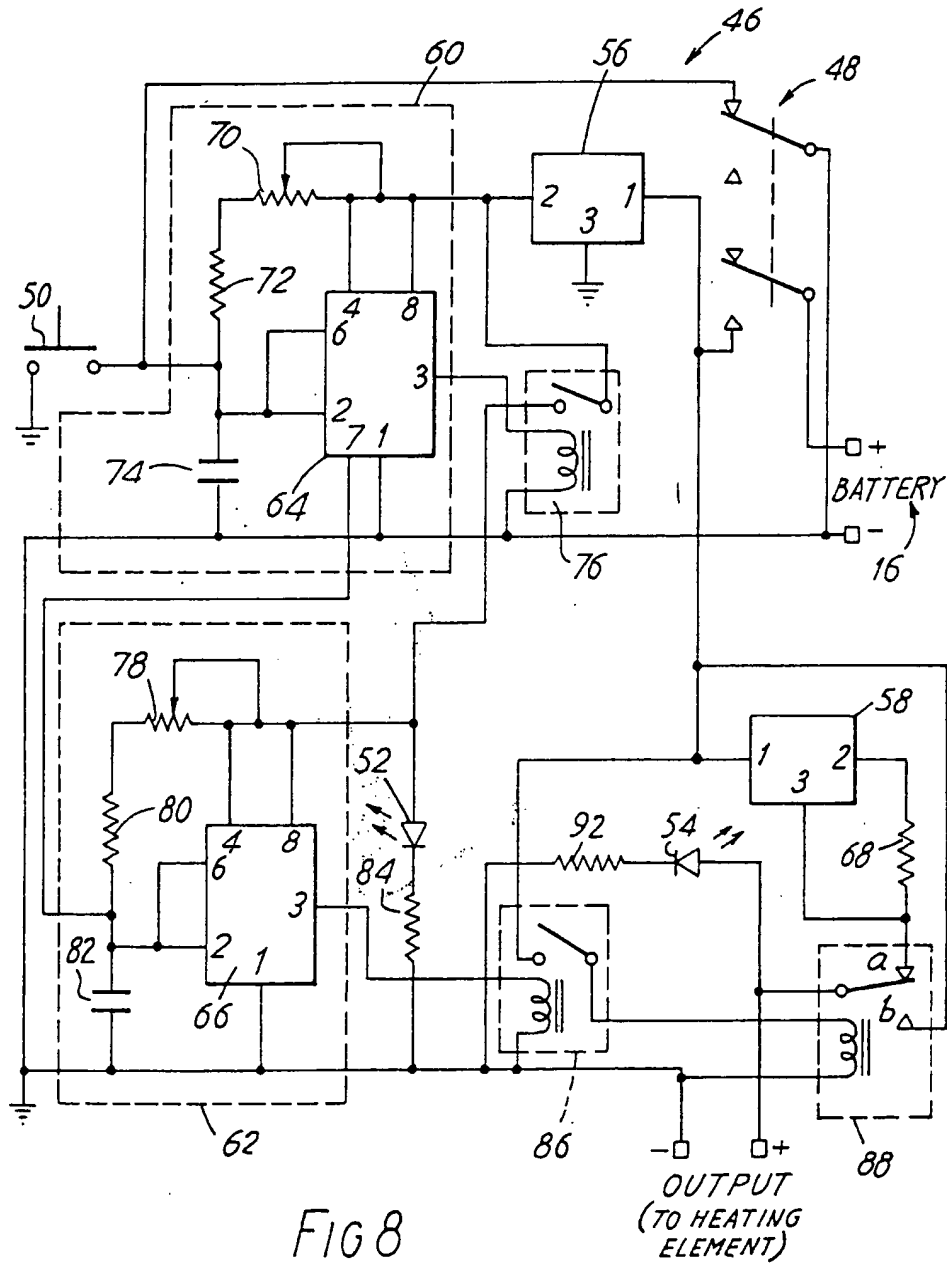

FIG 8

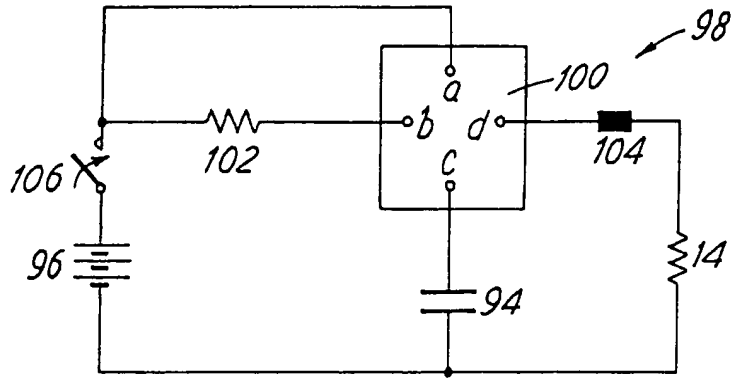

FIG. 10

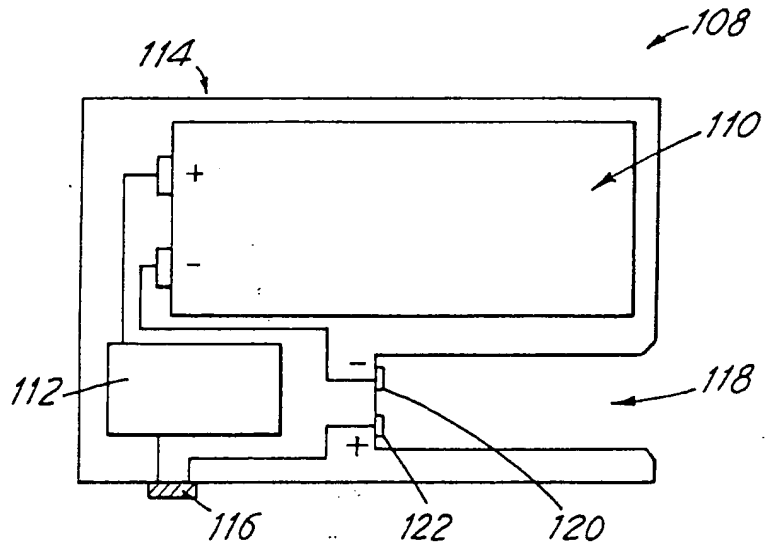

FIG. 11

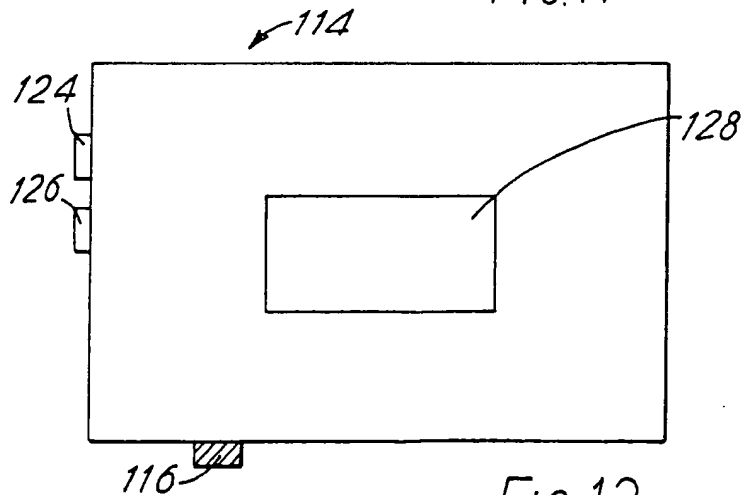

FIG. 12

